

4930

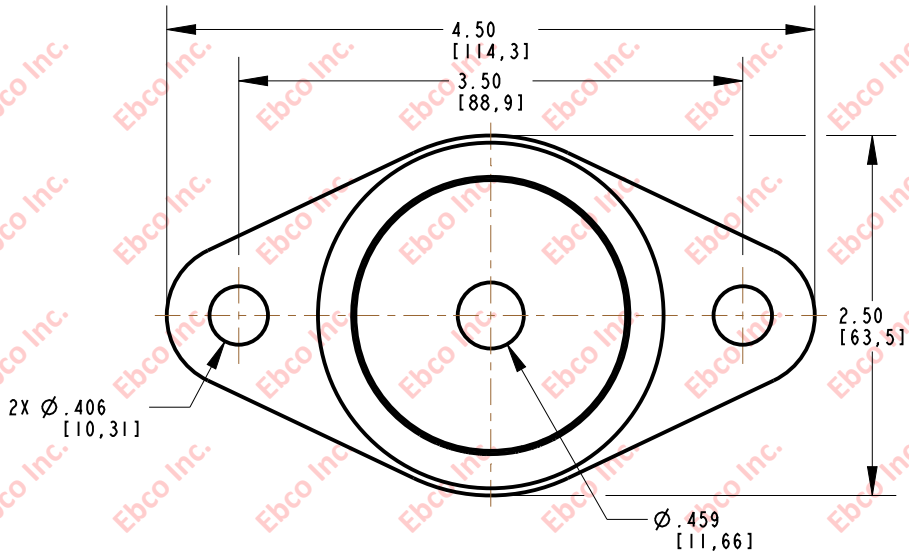

INSTALLATION VIEW (Shown under no load)

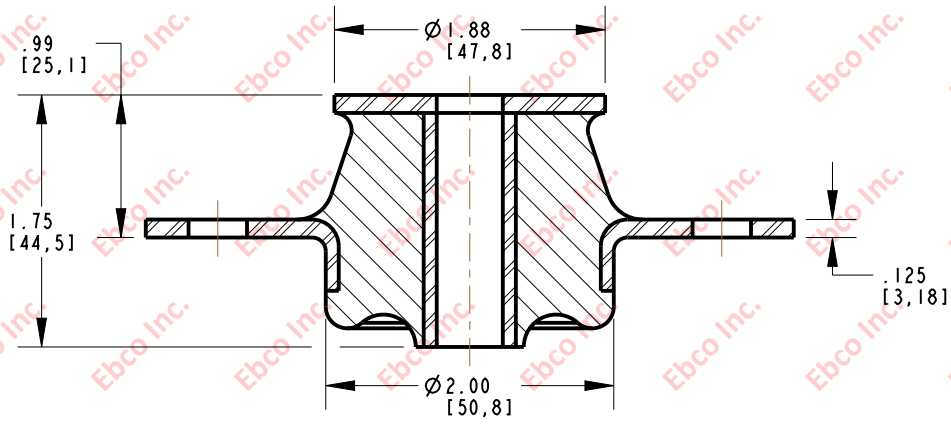
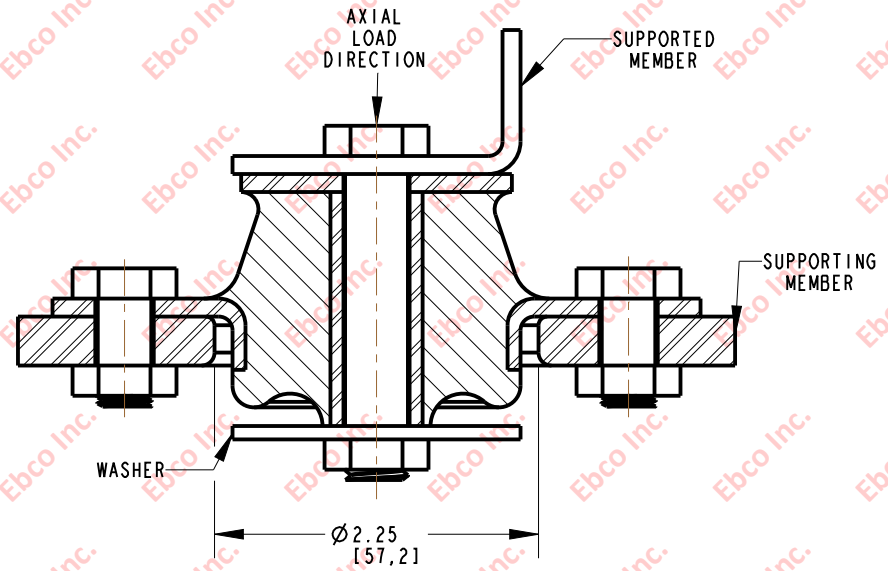

SPECIFICATIONS

PART NUMBER		MAX. AXIAL DEFLECTION		MAX. AXIAL LOAD	
NATURAL RUBBER	NEOPRENE	in	mm	lb	N
4930-70	4930-80	0.15	3.81	115	512
4930-71	4930-81			140	623
4930-72	4930-82			175	779
4930-73	4930-83			225	1001
4930-74	4930-84			260	1157
4930-75	4930-85			310	1379
4930-77	4930-87			400	1780
4930-78	4930-88			600	2669

INSTALLATION DIMENSIONS

RECOMMENDED BOLT INFORMATION				TIGHTENING TORQUE			
ENGLISH		METRIC		CLAMP LOAD		TIGHTENING TORQUE	
SIZE	GRADE	SIZE	CLASS	lb	N	ft-lb	N-m
7/16	5	M10	9.8	6777	30146	49.40	66.90
WASHER SPECIFICATIONS							
O. D.		I. D.		THICKNESS			
in	mm	in	mm	in	mm		
2.00	50.80	0.45	11.43	.125	3.18		



TITLE: 4930	
THE INFORMATION CONTAINED IN THIS DRAWING IS THE SOLE PROPERTY OF EBCO. ANY REPRODUCTION IN PART OR AS A WHOLE WITHOUT THE WRITTEN PERMISSION OF EBCO IS PROHIBITED.	
TOLERANCES PER RMA STANDARD A3	REV. D
DATE: 04-25-17	UNITS: [INCH] [MM]
1330 HOLMES RD. ELGIN, IL 60123	

SPECIFICATIONS SUBJECT TO CHANGE