

4880

DMG NO.

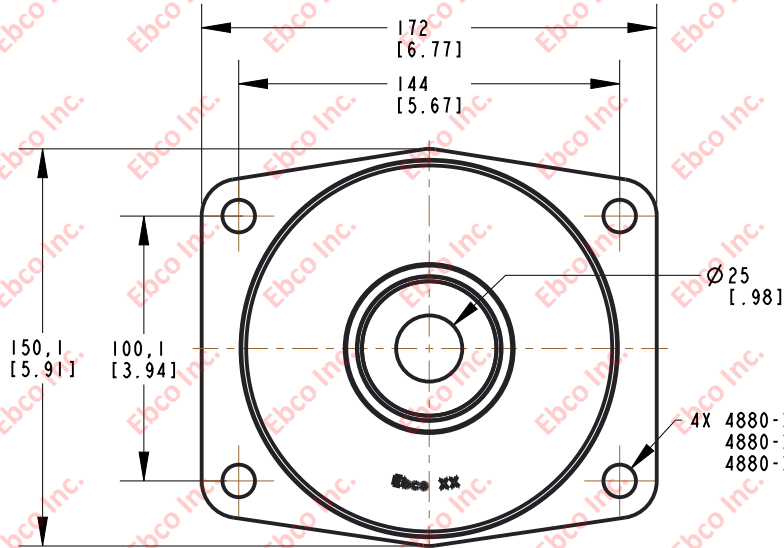

- 4X 4880-XX-A : \varnothing 10.92 [.430]
- 4880-XX-B : \varnothing 12.19 [.480]
- 4880-XX-C : \varnothing 13.25 [.522]

INSTALLATION VIEW (Shown under no load)

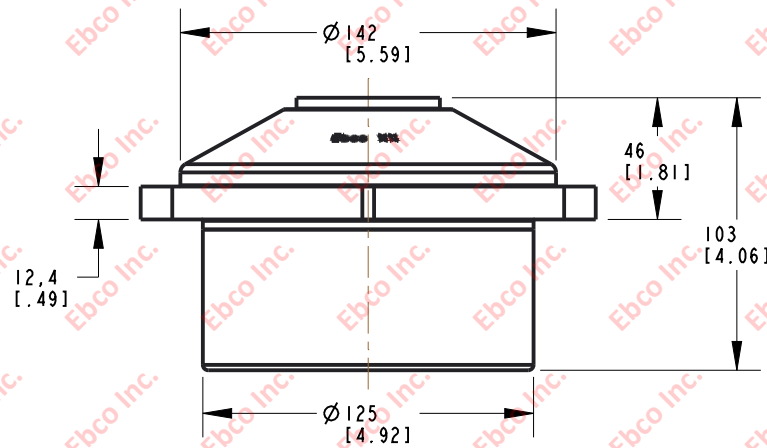
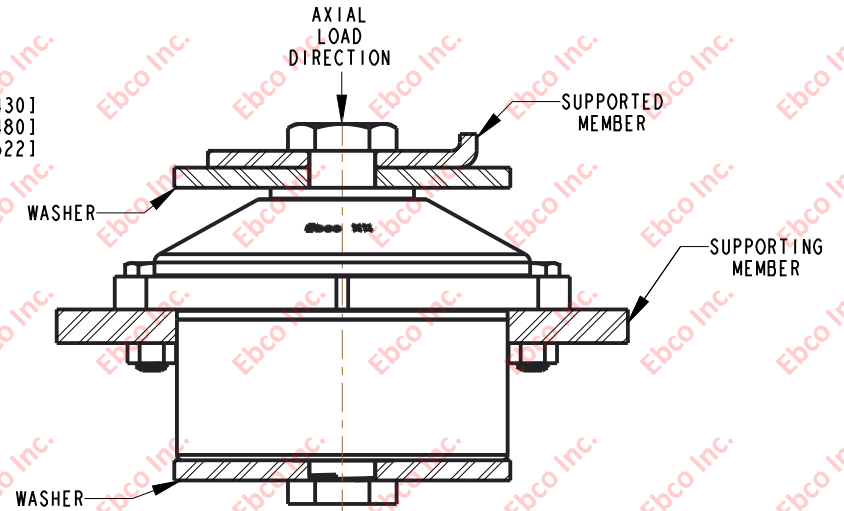

INSTALLATION DIMENSIONS

SPECIFICATIONS

PART NUMBER		MAX. AXIAL DEFLECTION		MAX. AXIAL LOAD	
NATURAL RUBBER	NEOPRENE	in	mm	lb	N
4880-71-X	4880-81-X	0.30	7.62	850	3780
4880-72-X	4880-82-X			1000	6228
4880-73-X	4880-83-X			1200	5340
4880-74-X	4880-84-X			1400	6227
4880-75-X	4880-85-X			1750	7787
4880-76-X	4880-86-X			2000	8896

RECOMMENDED BOLT INFORMATION				TIGHTENING TORQUE			
ENGLISH		METRIC		CLAMP LOAD		TIGHTENING TORQUE	
SIZE	GRADE	SIZE	CLASS	lb	kN	ft-lb	N-m
7/8	5	M22	9.8	29438	131	429	582
WASHER SPECIFICATIONS							
O. D.		I. D.		THICKNESS			
in	mm	in	mm	in	mm		
5	127	.957	24.31	.375	9.52		



TITLE: 4880	
THE INFORMATION CONTAINED IN THIS DRAWING IS THE SOLE PROPERTY OF EBCO ANY REPRODUCTION IN PART OR AS A WHOLE WITHOUT THE WRITTEN PERMISSION OF EBCO IS PROHIBITED.	
TOLERANCES PER RMA STANDARD A3	REV. F
DATE: 06-06-16	UNITS: mm [INCH]
1330 HOLMES RD. ELGIN, IL 60123	

SPECIFICATIONS SUBJECT TO CHANGE