

4701

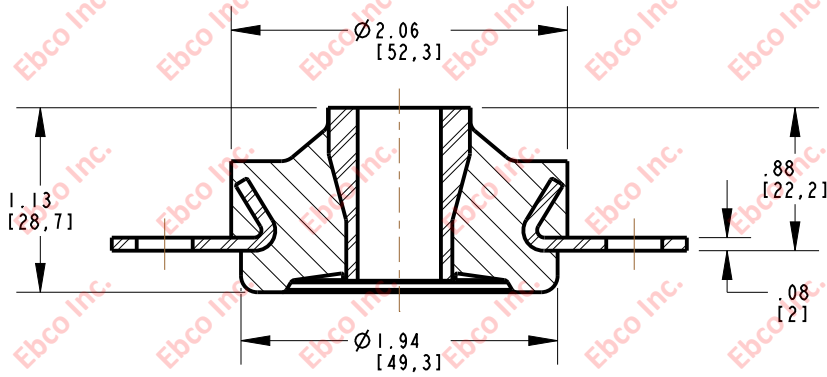

INSTALLATION VIEW (Shown under no load)

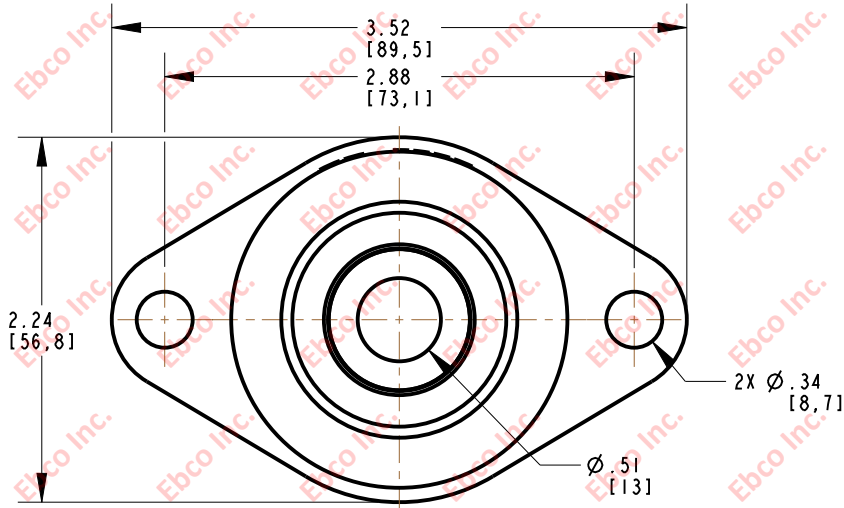
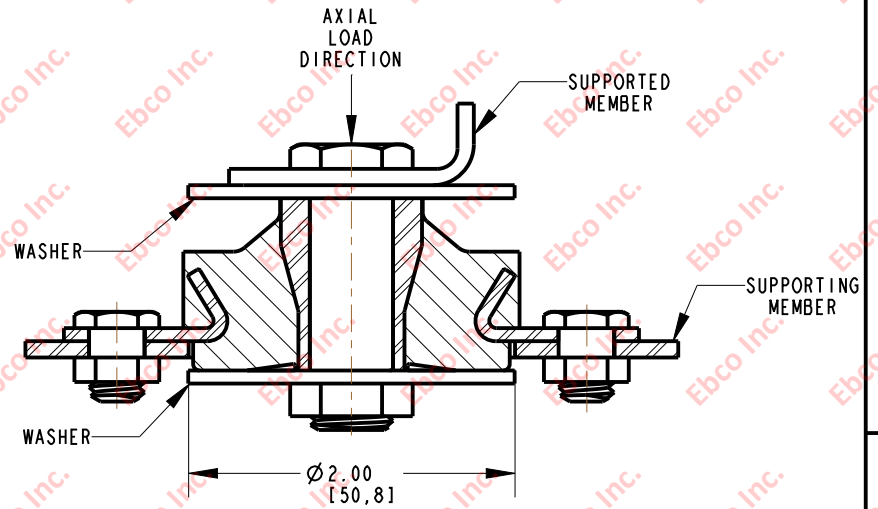

INSTALLATION DIMENSIONS

RECOMMENDED BOLT INFORMATION				TIGHTENING TORQUE			
ENGLISH		METRIC		CLAMP LOAD		TIGHTENING TORQUE	
SIZE	GRADE	SIZE	CLASS	lb	N	ft-lb	N-m
1/2	5	M12	9.8	9038	40203	75	102
WASHER SPECIFICATIONS							
O.D.		I.D.		THICKNESS			
in	mm	in	mm	in	mm		
2	50.8	.55	13.97	.1	2.54		

SPECIFICATIONS

PART NUMBER		MAX. AXIAL DEFLECTION		MAX. AXIAL LOAD	
NATURAL RUBBER	NEOPRENE	in	mm	lb	N
4701-70	4701-80	0.10	2.54	40	178
4701-72	4701-82			50	222
4701-74	4701-84			75	334
4701-75	4701-85			100	445
4701-76	4701-86			125	556
4701-77	4701-87			150	667



TITLE: 4701		
THE INFORMATION CONTAINED IN THIS DRAWING IS THE SOLE PROPERTY OF EBCO. ANY REPRODUCTION IN PART OR AS A WHOLE WITHOUT THE WRITTEN PERMISSION OF EBCO IS PROHIBITED.		
TOLERANCES PER RMA STANDARD A3	REV. B	DATE: 08-26-13 UNITS: INCH [MM]
1330 HOLMES RD. ELGIN, IL 60123		

SPECIFICATIONS SUBJECT TO CHANGE