

4635

DWG. NO.

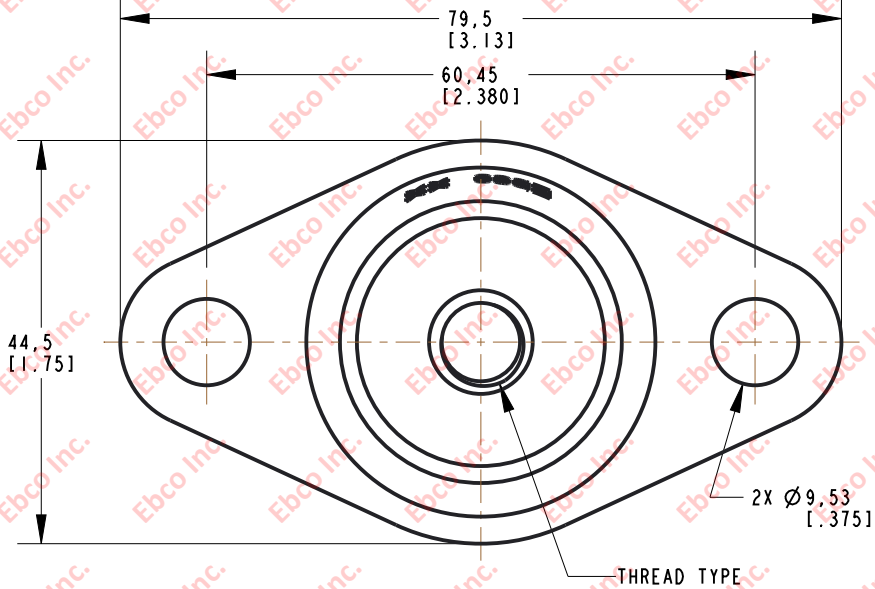

INSTALLATION VIEW (Shown under no load)

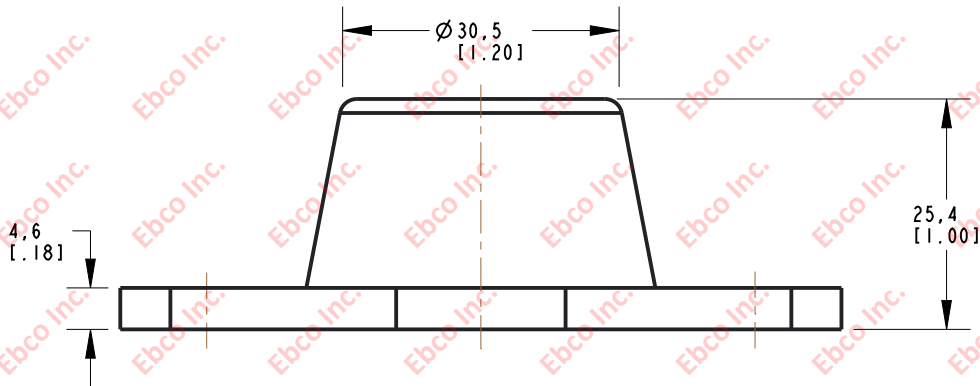
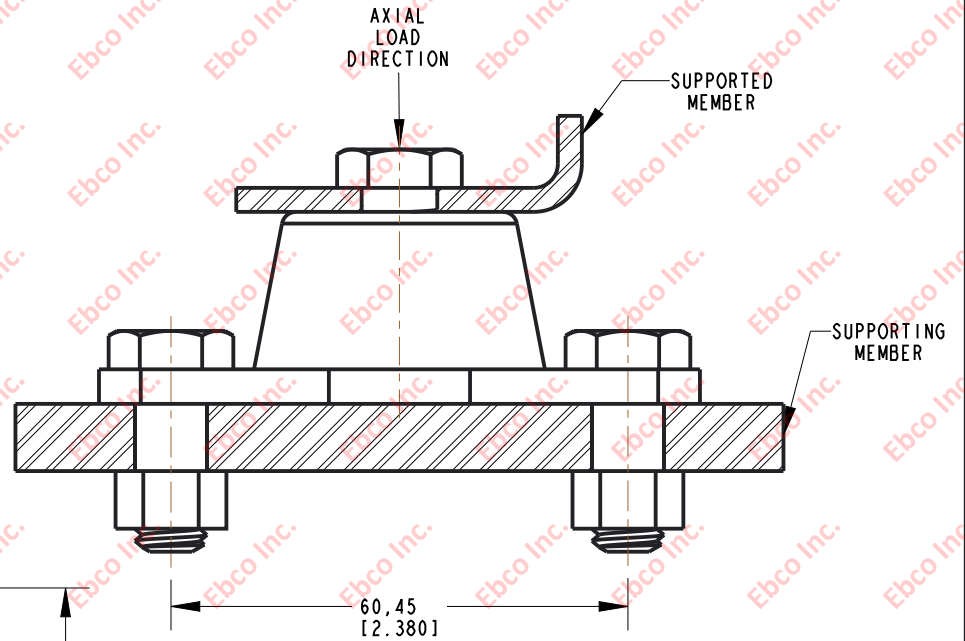

SPECIFICATIONS AND INSTALLATION DIMENSIONS

PART NUMBER		MAX. AXIAL DEFLECTION		MAX. AXIAL LOAD		THREAD TYPE
NATURAL RUBBER	NEOPRENE	in	mm	lb	N	
4635-70	4635-80	0.1	2.54	140	623	5/16
4635-70-S	4635-80-S					.375 [9.5], NO THREAD
4635-71	4635-81			170	756	5/16
4635-71-S	4635-81-S					.375 [9.5], NO THREAD
4635-73	4635-83			220	979	5/16
4635-73-S	4635-83-S					.375 [9.5], NO THREAD

TITLE: 4635

THE INFORMATION CONTAINED IN THIS DRAWING IS THE SOLE PROPERTY OF EBCO ANY REPRODUCTION IN PART OR AS A WHOLE WITHOUT THE WRITTEN PERMISSION OF EBCO IS PROHIBITED.

TOLERANCES PER RMA STANDARD A3	REV. C	DATE: 06-07-21
		UNITS: mm [INCH]

1330 HOLMES RD. ELGIN, IL 60123

SPECIFICATIONS SUBJECT TO CHANGE