

4285

IMP. NO.

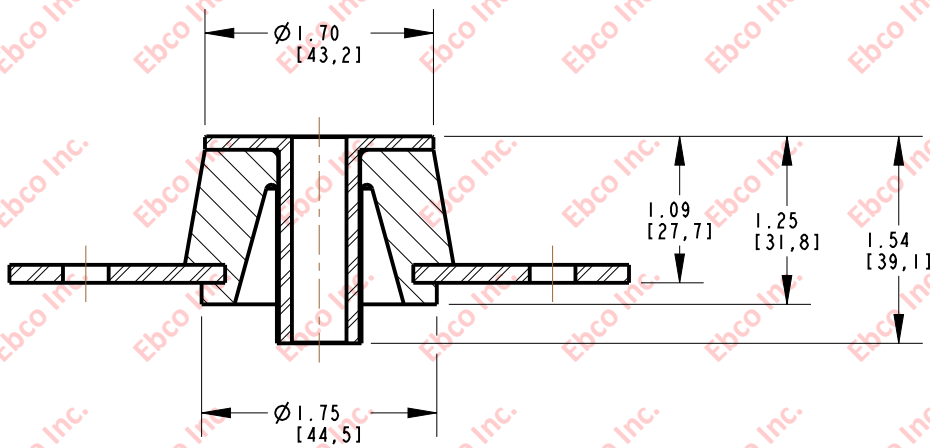

INSTALLATION VIEW (Shown under no load)

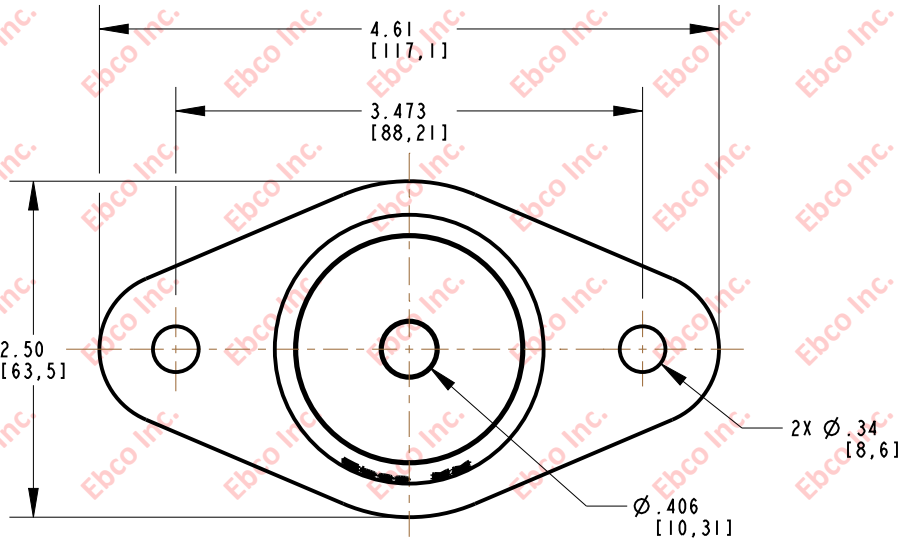
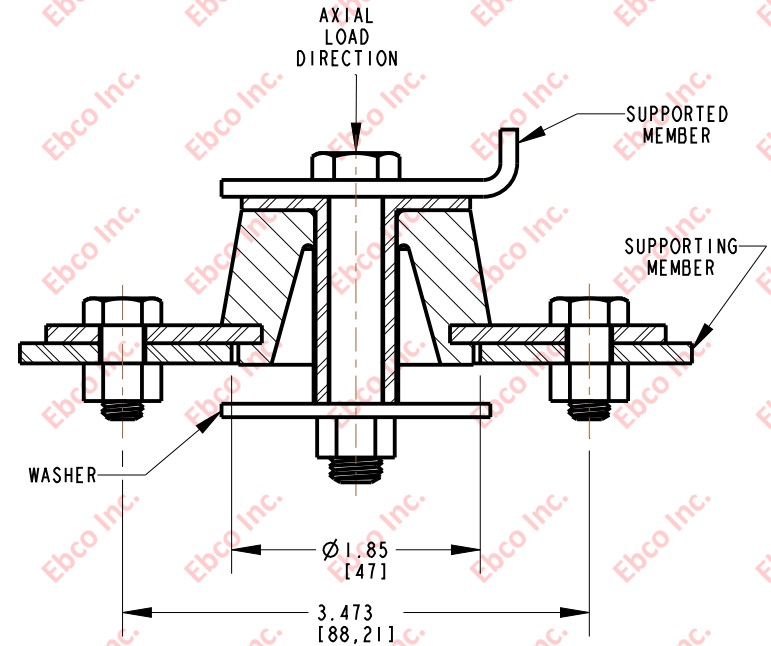

INSTALLATION DIMENSIONS

SPECIFICATIONS

PART NUMBER		MAX. AXIAL DEFLECTION		MAX. AXIAL LOAD	
NATURAL RUBBER	NEOPRENE	in	mm	lb	N
4285-71	4285-81	0.1	2.54	70	311
4285-72	4285-82			80	356
4285-74	4285-84			150	667
4285-75	4285-85			180	801
4285-76	4285-86			220	979

RECOMMENDED BOLT INFORMATION				TIGHTENING TORQUE			
ENGLISH		METRIC		CLAMP LOAD		TIGHTENING TORQUE	
SIZE	GRADE	SIZE	CLASS	lb	N	ft-lb	N-m
3/8	5	M10	9.8	4941	21979	30.9	41.7
WASHER SPECIFICATIONS							
O. D.		I. D.		THICKNESS			
in	mm	in	mm	in	mm		
2.00	50.80	.40	10.16	.125	3.18		



TITLE: 4285

THE INFORMATION CONTAINED IN THIS DRAWING IS THE SOLE PROPERTY OF EBCO. ANY REPRODUCTION IN PART OR AS A WHOLE WITHOUT THE WRITTEN PERMISSION OF EBCO IS PROHIBITED.

TOLERANCES PER RMA STANDARD A3

REV. C

DATE: 05-23-17

UNITS: INCH [MM]

1330 HOLMES RD. ELGIN, IL 60123

SPECIFICATIONS SUBJECT TO CHANGE