

4280

IMP. NO.

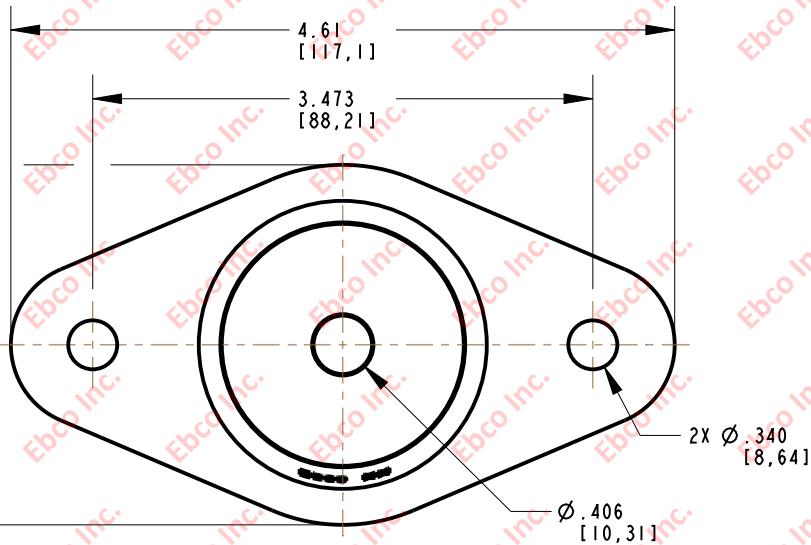

INSTALLATION VIEW (Shown under no load)

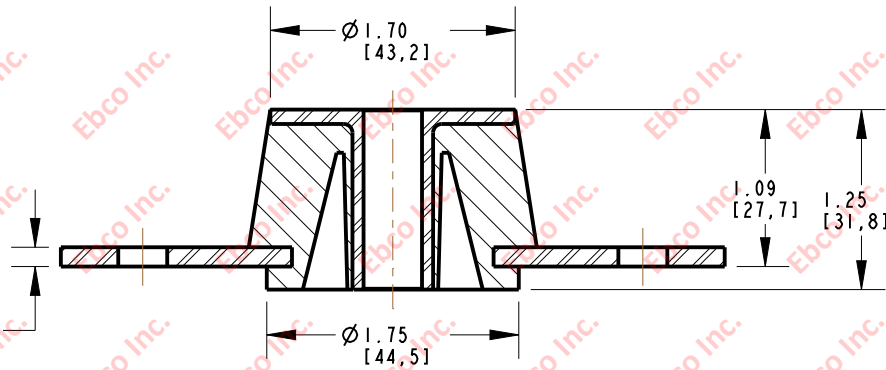
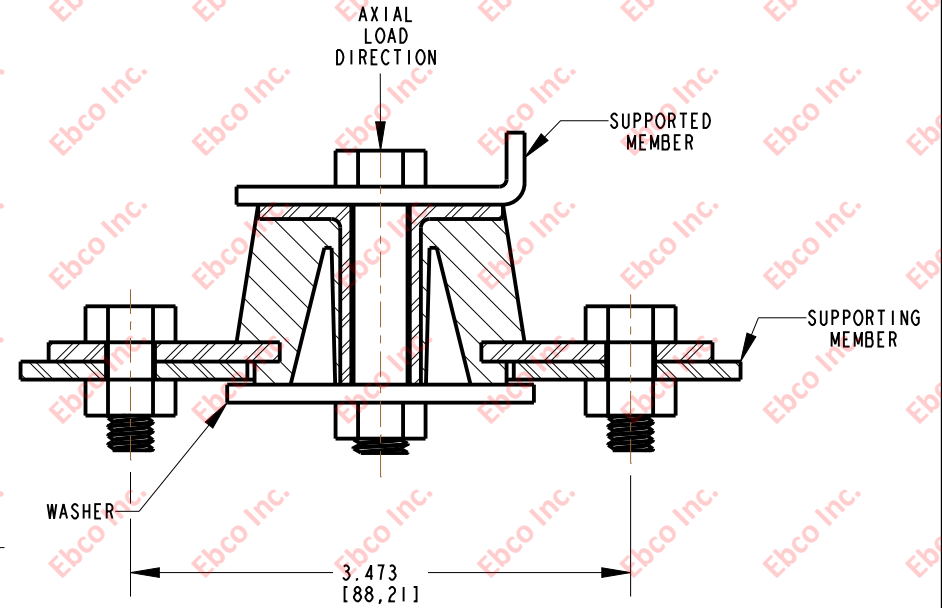

INSTALLATION DIMENSIONS

SPECIFICATIONS

PART NUMBER		MAX. AXIAL DEFLECTION		MAX. AXIAL LOAD	
NATURAL RUBBER	NEOPRENE	in	mm	lb	N
4280-71	4280-81	.10	2.54	70	311
4280-73	4280-83			100	445
4280-74	4280-84			150	667
4280-75	4280-85			200	890
4280-76	4280-86			250	1112
4280-77	4280-87			300	1335

RECOMMENDED BOLT INFORMATION				TIGHTENING TORQUE			
ENGLISH		METRIC		CLAMP LOAD		TIGHTENING TORQUE	
SIZE	GRADE	SIZE	CLASS	lb	N	ft-lb	N-m
3/8	5	M10	9.8	4941	21979	30.9	41.72

WASHER SPECIFICATIONS					
O. D.		I. D.		THICKNESS	
in	mm	in	mm	in	mm
2.13	54.10	.40	10.16	.125	3.18



TITLE: 4280  
 THE INFORMATION CONTAINED IN THIS DRAWING IS THE SOLE PROPERTY OF EBCO. ANY REPRODUCTION IN PART OR AS A WHOLE WITHOUT THE WRITTEN PERMISSION OF EBCO IS PROHIBITED.  
 TOLERANCES PER RMA STANDARD A3  
 REV. C  
 DATE: 09-22-16  
 UNITS: INCH [MM]  
 1330 HOLMES RD. ELGIN, IL 60123

SPECIFICATIONS SUBJECT TO CHANGE