

4249

DWG. NO.

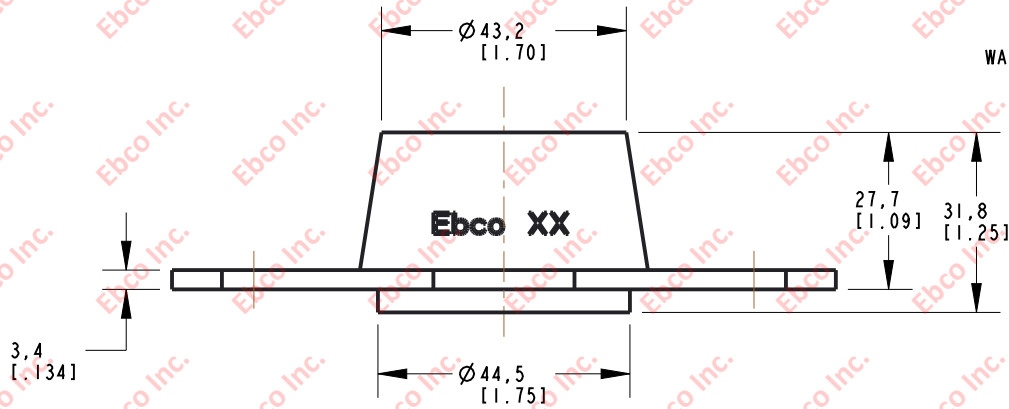

INSTALLATION VIEW (Shown under no load)

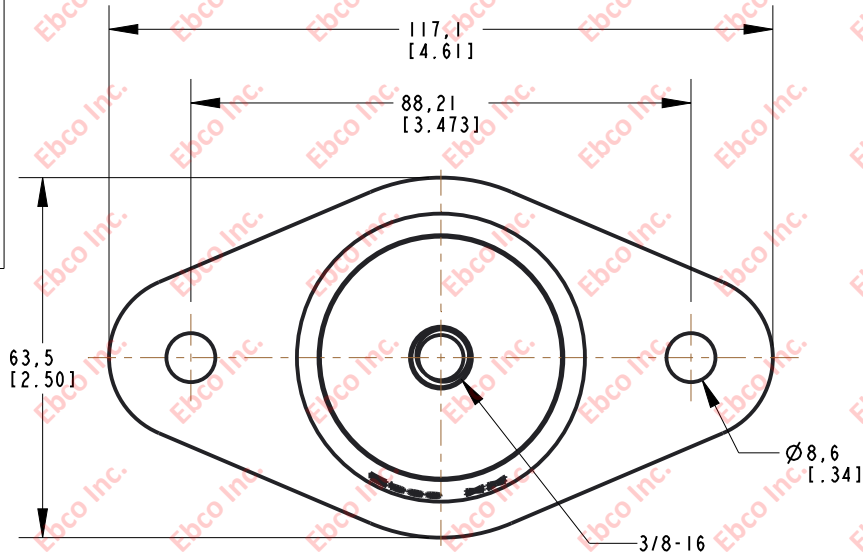
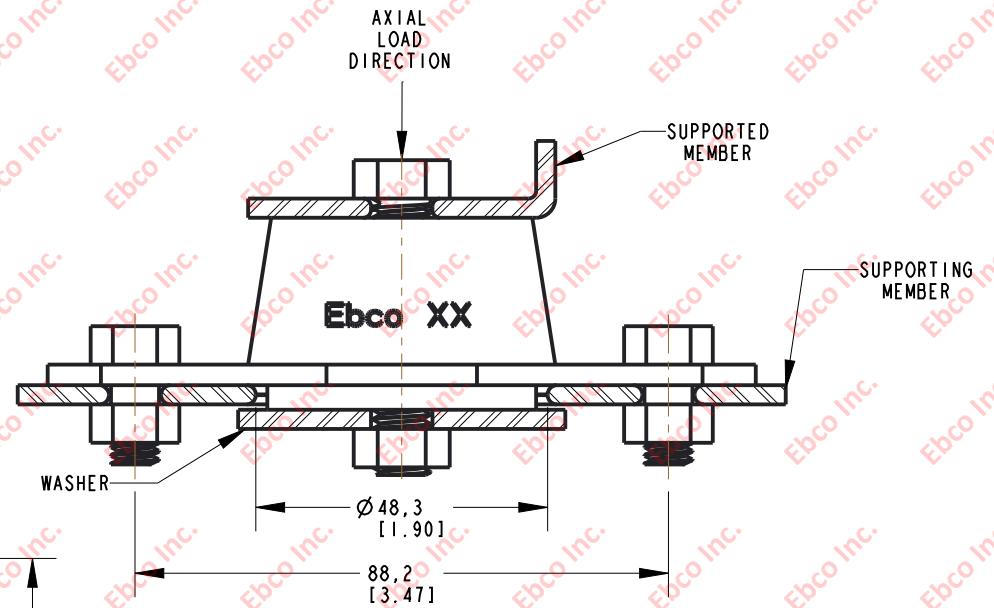

INSTALLATION DIMENSIONS

SPECIFICATIONS

PART NUMBER		MAX. AXIAL DEFLECTION		MAX. AXIAL LOAD	
NATURAL RUBBER	NEOPRENE	in	mm	lb	N
4249-71	4249-81	0.1	2.54	70	311
4249-72	4249-82			80	356
4249-74	4249-84			150	667
4249-75	4249-85			200	889
4249-76	4249-86			250	1112

BOLT INFORMATION		TIGHTENING TORQUE			
ENGLISH		CLAMP LOAD	TIGHTENING TORQUE		
SIZE	GRADE	lb	ft-lb		
3/8-16	5	4941	30.9		
WASHER SPECIFICATIONS					
O. D.		I. D.		THICKNESS	
in	mm	in	mm	in	mm
2.13	54.10	.40	10.16	.125	3.18



TITLE:	4249
THE INFORMATION CONTAINED IN THIS DRAWING IS THE SOLE PROPERTY OF EBCO ANY REPRODUCTION IN PART OR AS A WHOLE WITHOUT THE WRITTEN PERMISSION OF EBCO IS PROHIBITED.	
TOLERANCES PER RMA STANDARD A3	REV. F
DATE: 06-04-21	UNITS: mm [INCH]

1330 HOLMES RD. ELGIN, IL 60123

SPECIFICATIONS SUBJECT TO CHANGE