

4249

IMP. NO.

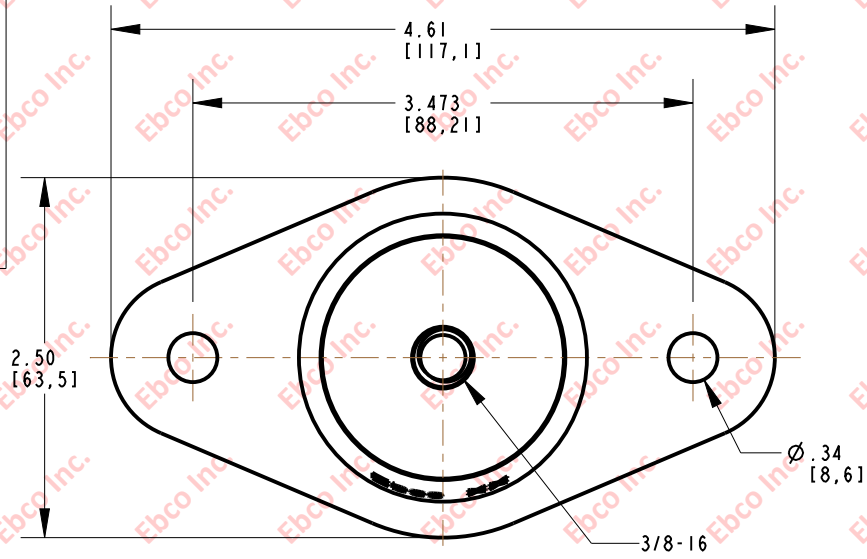

INSTALLATION VIEW (Shown under no load)

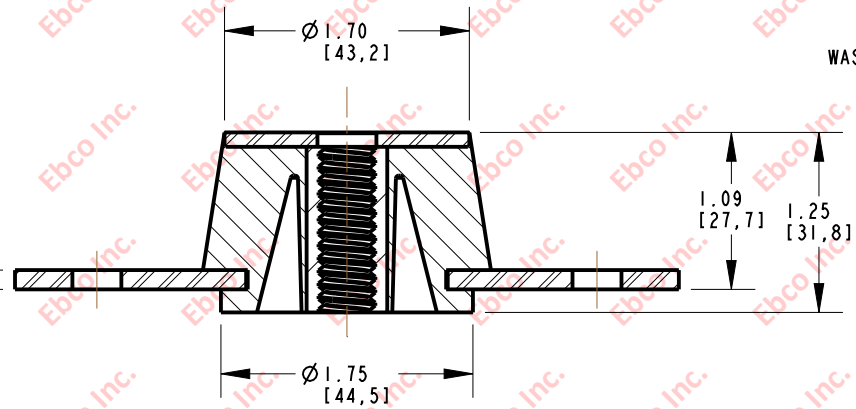
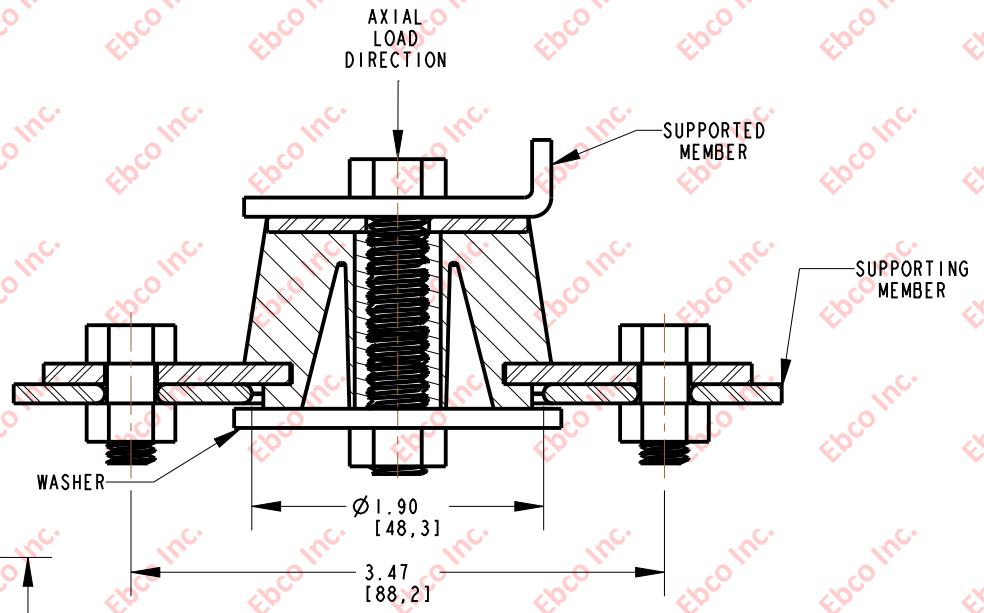

INSTALLATION DIMENSIONS

BOLT INFORMATION		TIGHTENING TORQUE			
ENGLISH		CLAMP LOAD	TIGHTENING TORQUE		
SIZE	GRADE	lb	ft-lb		
3/8-16	5	4941	30.9		
WASHER SPECIFICATIONS					
O.D.		I.D.		THICKNESS	
in	mm	in	mm	in	mm
2.13	54.10	.40	10.16	.125	3.18

SPECIFICATIONS

PART NUMBER		MAX. AXIAL DEFLECTION		MAX. AXIAL LOAD	
NATURAL RUBBER	NEOPRENE	in	mm	lb	N
4249-71	4249-81	0.1	2.54	70	311
4249-72	4249-82			80	356
4249-74	4249-84			150	667
4249-75	4249-85			200	889
4249-76	4249-86			250	1112



TITLE:	4249	
THE INFORMATION CONTAINED IN THIS DRAWING IS THE SOLE PROPERTY OF EBCO ANY REPRODUCTION IN PART OR AS A WHOLE WITHOUT THE WRITER PERMISSION OF EBCO IS PROHIBITED.		
TOLERANCES PER RMA STANDARD	REV. E	DATE: 11-28-17
A3		UNITS: INCH [MM]
1330 HOLMES RD. ELGIN, IL 60123		

SPECIFICATIONS SUBJECT TO CHANGE