

3551

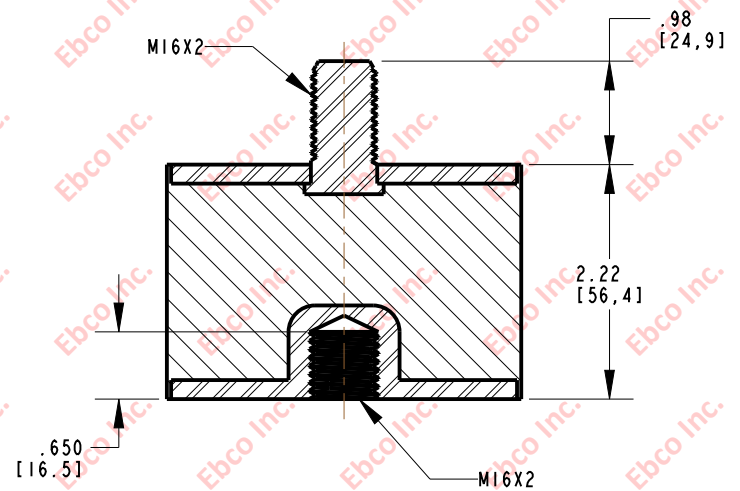

SPECIFICATIONS

PART NUMBER		MAX. AXIAL DEFLECTION		MAX. AXIAL LOAD	
NATURAL RUBBER	NEOPRENE	i n	mm	l b	N
3551-145	3551-045	0.20	5.08	440	1957
3551-150	3551-050			530	2358
3551-155	3551-055			650	2891
3551-160	3551-060			800	3559
3551-165	3551-065			950	4226
3551-170	3551-070			1140	5071
3551-175	3551-075			1400	6228
3551-180	3551-080			1800	8007

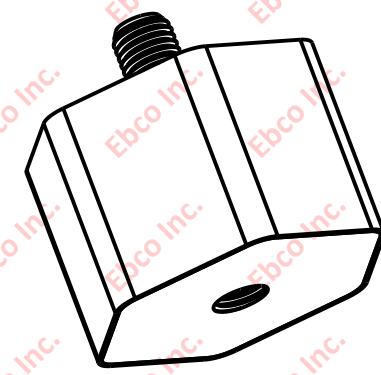
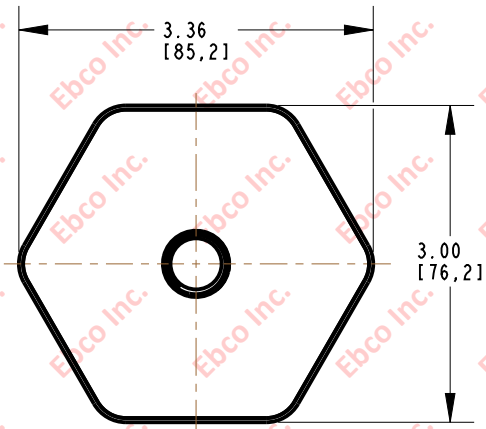

TITLE: 3551		
THE INFORMATION CONTAINED IN THIS DRAWING IS THE SOLE PROPERTY OF EBCO. ANY REPRODUCTION IN PART OR AS A WHOLE WITHOUT THE WRITTEN PERMISSION OF EBCO IS PROHIBITED.		
TOLERANCES PER RMA STANDARD A3	REV. 01	DATE: 08-04-14
		UNITS: INCH [MM]
1330 HOLMES RD. ELGIN, IL 60123		

SPECIFICATIONS SUBJECT TO CHANGE