

2663

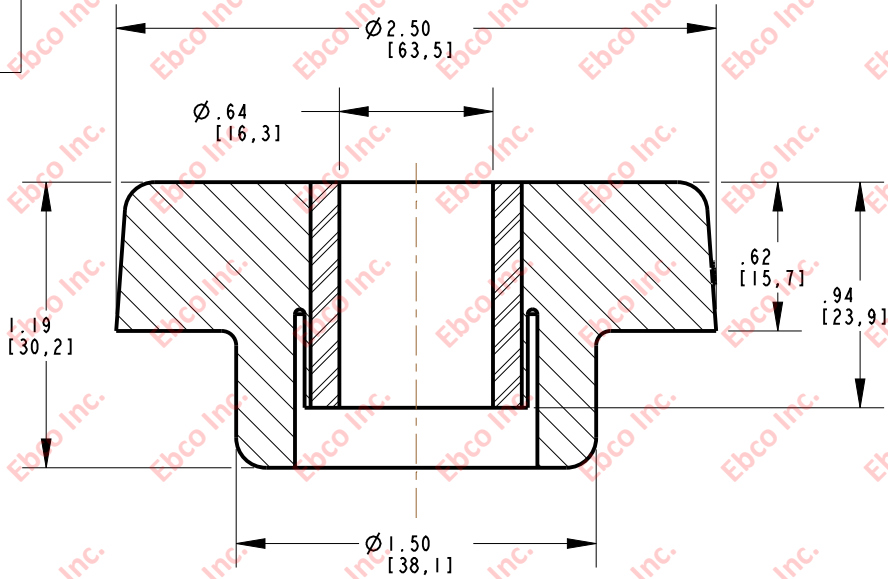

INSTALLATION VIEW (Shown under no load)

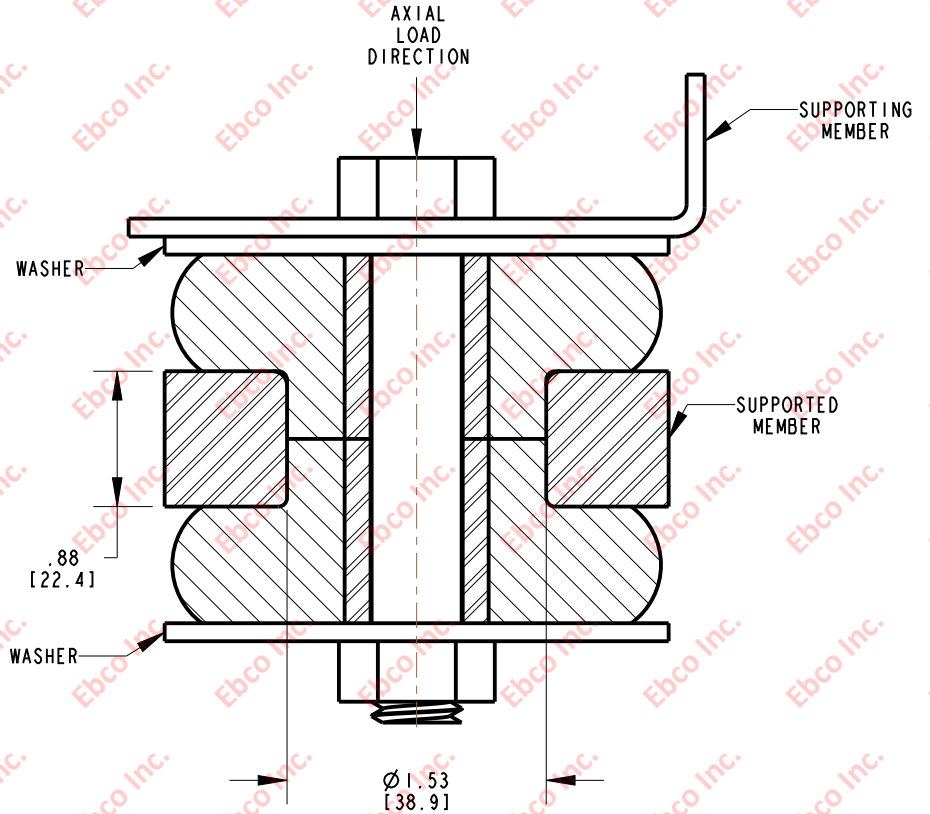

INSTALLATION DIMENSIONS

RECOMMENDED BOLT INFORMATION				TIGHTENING TORQUE			
ENGLISH		METRIC		CLAMP LOAD		TIGHTENING TORQUE	
SIZE	GRADE	SIZE	CLASS	lb	N	ft-lb	N-m
5/8	5	M16	9.8	14408	64090	150	203

WASHER SPECIFICATIONS

O. D.		I. D.		THICKNESS	
in	mm	in	mm	in	mm
2.88	73.15	.64	16.26	.125	3.18

SPECIFICATIONS

PART NUMBER		MAX. AXIAL DEFLECTION		MAX. AXIAL LOAD	
NATURAL RUBBER	NEOPRENE	in	mm	lb	N
2663-73	2663-83	.04	1.02	525	2335
2663-75	2663-85			850	3781
2663-77	2663-87			1200	5338



TITLE:	2663	
THE INFORMATION CONTAINED IN THIS DRAWING IS THE SOLE PROPERTY OF EBCU. ANY REPRODUCTION IN PART OR AS A WHOLE WITHOUT THE WRITTEN PERMISSION OF EBCU IS PROHIBITED.		
TOLERANCES PER RMA STANDARD A3	REV. B	DATE: 08-13-13
		UNITS: [INCH] [MM]
1330 HOLMES RD. ELGIN, IL 60123		

SPECIFICATIONS SUBJECT TO CHANGE