

2610

IMP. NO.

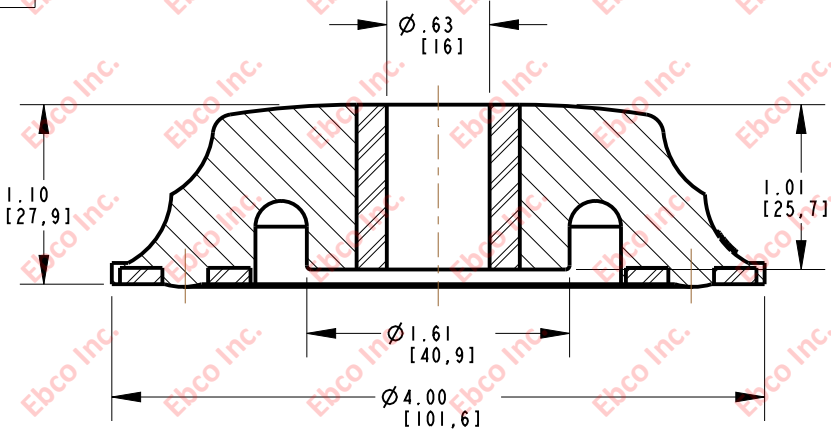

INSTALLATION DRAWING (Shown under no load)

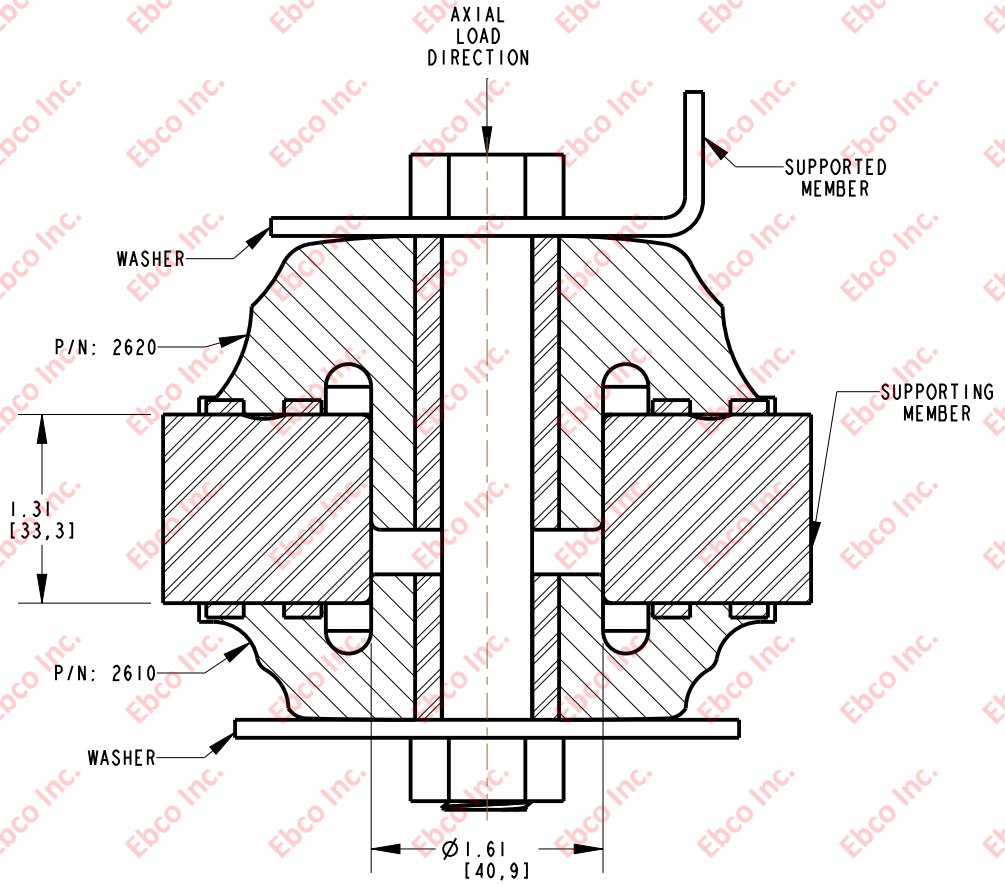

INSTALLATION DIMENSIONS

RECOMMENDED BOLT INFORMATION				TIGHTENING TORQUE			
ENGLISH		METRIC		CLAMP LOAD		TIGHTENING TORQUE	
SIZE	GRADE	SIZE	CLASS	lb	N	ft-lb	N-m
5/8	5	M16	9.8	12612	157	132	157

WASHER SPECIFICATIONS					
O. D.		I. D.		THICKNESS	
in	mm	in	mm	in	mm
3.50	88.90	.63	16.00	.125	3.18

SPECIFICATIONS

PART NUMBER		MAX. AXIAL DEFLECTION		MAX. AXIAL LOAD	
NATURAL RUBBER	NEOPRENE	in	mm	lb	N
2610-73	2610-83	0.10	2.54	550	2447
2610-75	2610-85			1000	4448



TITLE: 2610

THE INFORMATION CONTAINED IN THIS DRAWING IS THE SOLE PROPERTY OF EBCO ANY REPRODUCTION IN PART OR AS A WHOLE WITHOUT THE WRITTEN PERMISSION OF EBCO IS PROHIBITED.

TOLERANCES PER RMA STANDARD A3

REV. C

DATE: 08-13-13

UNITS: INCH [MM]

1330 HOLMES RD. ELGIN, IL 60123

SPECIFICATIONS SUBJECT TO CHANGE