

2490

DWG. NO.

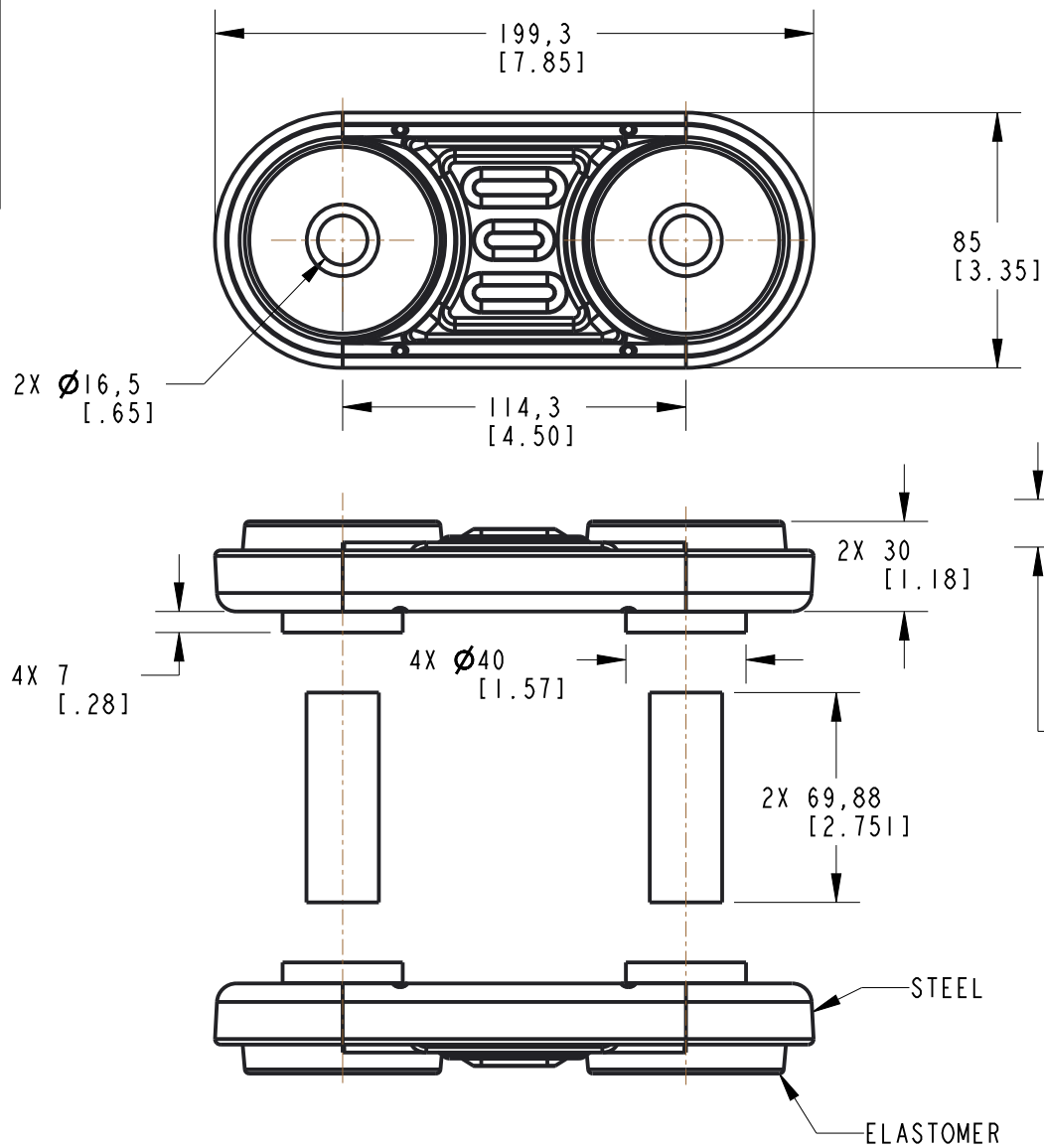

INSTALLATION VIEW (Shown under no load)

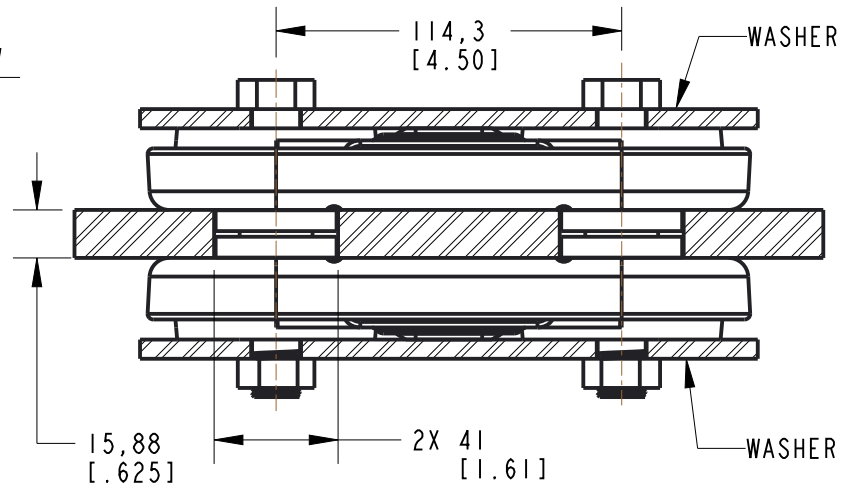

SPECIFICATION

PART NUMBER		MAX. AXIAL DEFLECTION		MAX. AXIAL LOAD	
NATURAL RUBBER	NEOPRENE	in	mm	lb	N
2490-75	2490-85	.09	2.29	2000	8896
2490-76	2490-86			2400	10676
2490-77	2490-87			3200	14234



TITLE: 2490

THE INFORMATION CONTAINED IN THIS DRAWING IS THE SOLE PROPERTY OF EBCO. ANY REPRODUCTION IN PART OR AS A WHOLE WITHOUT THE WRITTEN PERMISSION OF EBCO IS PROHIBITED.

TOLERANCES PER RMA STANDARD A3	REV. A	DATE: 02-01-22
		UNITS: mm [INCH]

1330 HOLMES RD. ELGIN, IL 60123

SPECIFICATIONS SUBJECT TO CHANGE