

2454

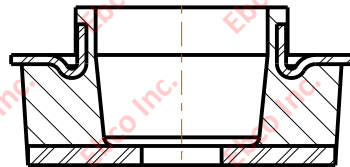

INSTALLATION VIEW (Shown under no load)

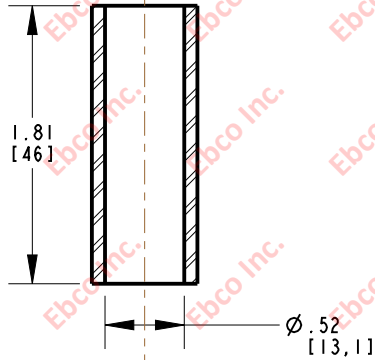
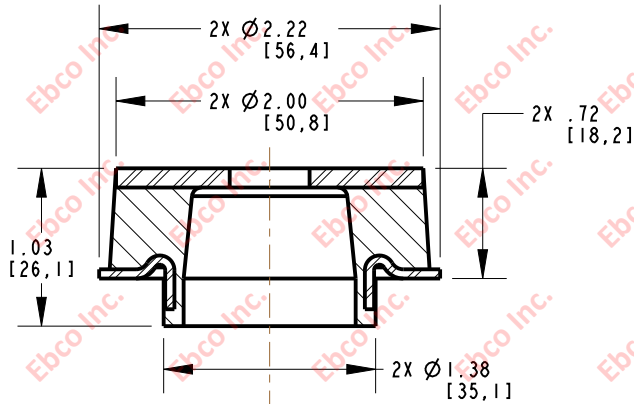
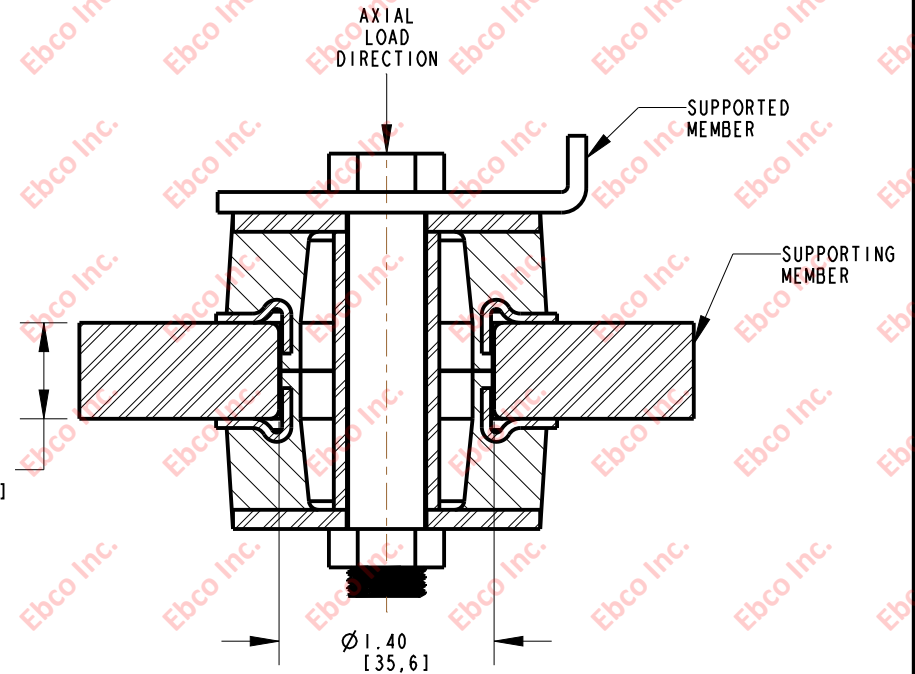

SPECIFICATIONS

PART NUMBER		MAX. AXIAL DEFLECTION		MAX. AXIAL LOAD	
NATURAL RUBBER	NEOPRENE	in	mm	lb	N
2454-73	2454-83	.035	.90	170	756
2454-74	2454-84			220	979
2454-75	2454-85			280	1246

INSTALLATION DIMENSIONS

RECOMMENDED BOLT INFORMATION				TIGHTENING TORQUE			
ENGLISH		METRIC		CLAMP LOAD		TIGHTENING TORQUE	
SIZE	GRADE	SIZE	CLASS	lb	N	ft-lb	N-m
1/2	5	M12	9.8	9046	40239	75.4	101.8



TITLE:		2454	
THE INFORMATION CONTAINED IN THIS DRAWING IS THE SOLE PROPERTY OF EBCU. ANY REPRODUCTION IN PART OR AS A WHOLE WITHOUT THE WRITTEN PERMISSION OF EBCU IS PROHIBITED.			
TOLERANCES PER RMA STANDARD A3	REV. A	DATE: 07-23-14	UNITS INCH [MM]
1330 HOLMES RD. ELGIN, IL 60123			

SPECIFICATIONS SUBJECT TO CHANGE