

2440

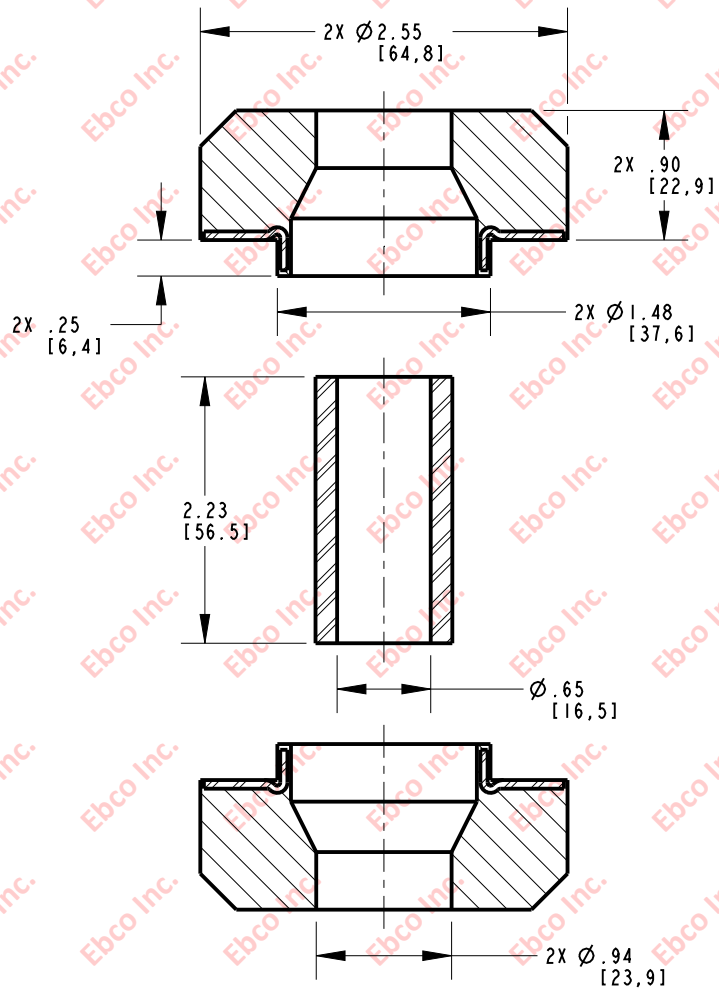

INSTALLATION VIEW (Shown under no load)

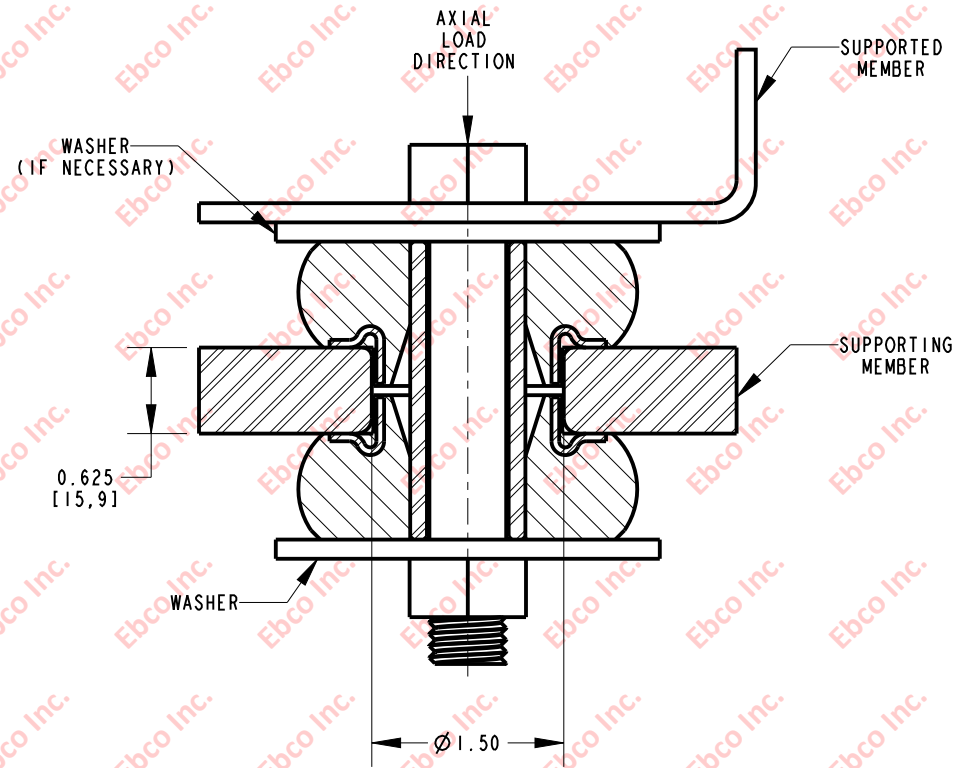

INSTALLATION DIMENSIONS

SPECIFICATIONS

PART NUMBER		MAX. AXIAL DEFLECTION		MAX. AXIAL LOAD	
NATURAL RUBBER	NEOPRENE	in	mm	lb	N
2440-73	2440-83	.09	2.29	350	1557
2440-74	2440-84			450	2002
2440-75	2440-85			550	2447
2440-76	2440-86			675	3004
2440-77	2440-87			850	3780
2440-78	2440-88			1050	4672
2440-79	2440-89			1300	5783

RECOMMENDED BOLT INFORMATION				TIGHTENING TORQUE			
ENGLISH		METRIC		CLAMP LOAD		TIGHTENING TORQUE	
SIZE	GRADE	SIZE	CLASS	lb	N	ft-lb	N-m
5/8	5	M16	9.8	14408	64090	150	203
WASHER SPECIFICATIONS							
O.D.		I.D.		THICKNESS			
in	mm	in	mm	in	mm		
2.88	73.15	.64	16.26	.125	3.18		



TITLE:	2440		
THE INFORMATION CONTAINED IN THIS DRAWING IS THE SOLE PROPERTY OF EBCO ANY REPRODUCTION IN PART OR AS A WHOLE WITHOUT THE WRITTEN PERMISSION OF EBCO IS PROHIBITED.			
TOLERANCES PER RMA STANDARD	REV. C	DATE: 04-14-15	UNITS: INCH [MM]
A3			
1330 HOLMES RD. ELGIN, IL 60123			

SPECIFICATIONS SUBJECT TO CHANGE