

2361

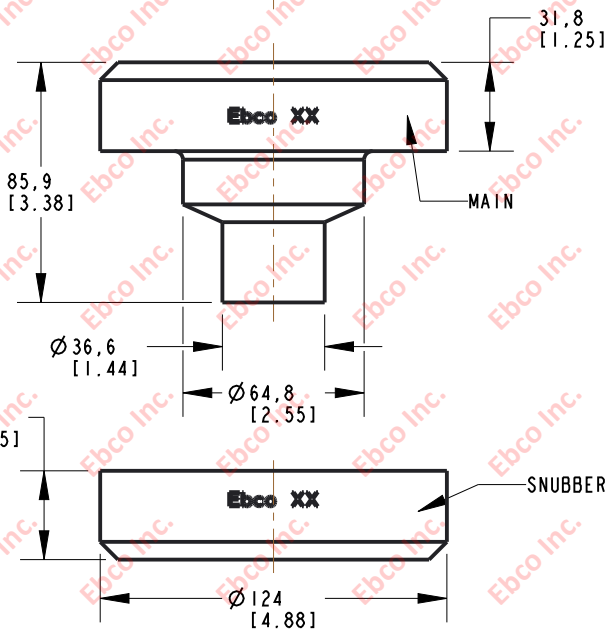

INSTALLATION VIEW (Shown under no load)

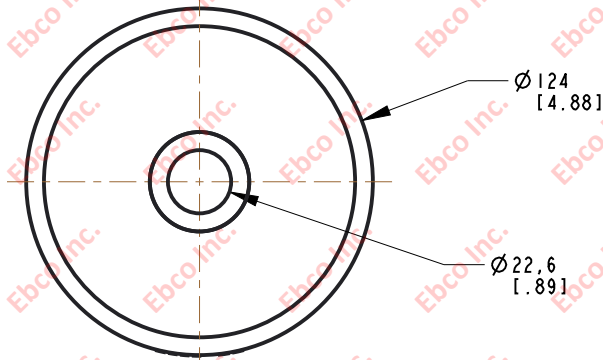
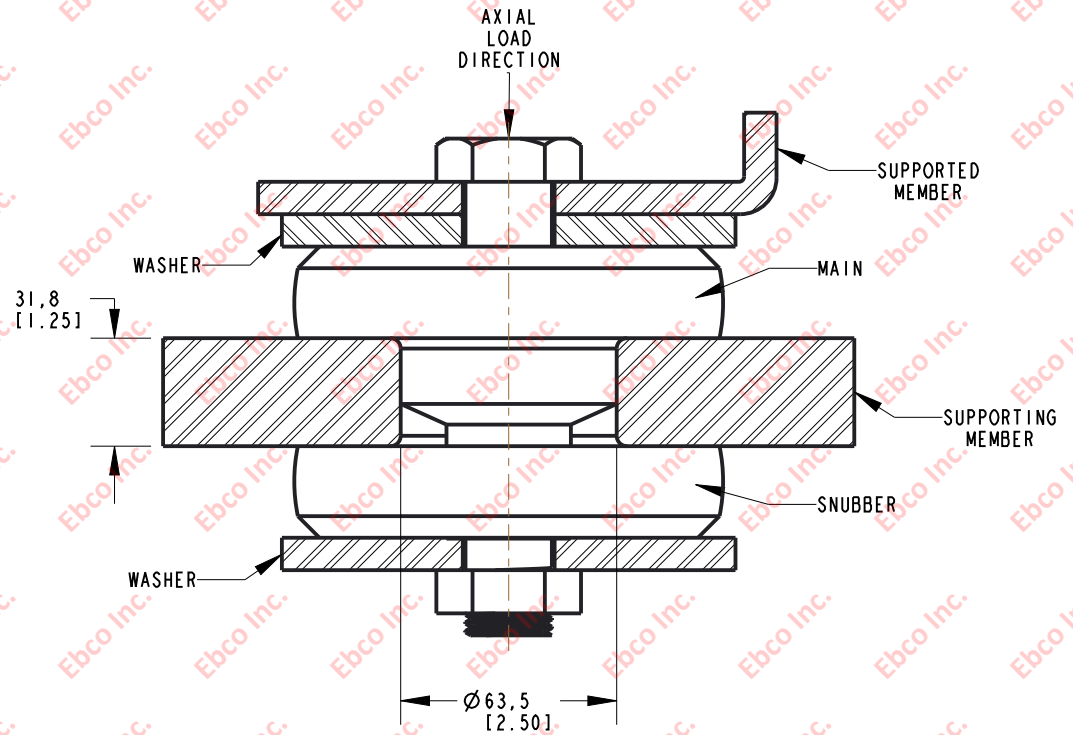

SPECIFICATIONS

PART NUMBER		MAX. AXIAL DEFLECTION		MAX. AXIAL LOAD	
NATURAL RUBBER	NEOPRENE	in	mm	lb	N
2361-70	2361-80	.12	3.05	1200	5338
2361-71	2361-81			1700	7565
2361-72	2361-82			2000	8900
2361-73	2361-83			2250	10012
2361-74	2361-84			2650	11792
2361-75	2361-85			3200	14234
2361-76	2361-86			3700	16465
2361-77	2361-87			4600	20470
2361-78	2361-88			5000	22250

INSTALLATION DIMENSIONS

RECOMMENDED BOLT INFORMATION				TIGHTENING TORQUE			
ENGLISH		METRIC		CLAMP LOAD		TIGHTENING TORQUE	
SIZE	GRADE	SIZE	CLASS	lb	N	ft-lb	N-m
7/8	5	M20	9.8	29453	119000	430	478
WASHER SPECIFICATIONS							
O. D.		I. D.		THICKNESS			
in	mm	in	mm	in	mm		
5.25	133.35	.938	23.83	.375	9.52		



TITLE: 2361
 THE INFORMATION CONTAINED IN THIS DRAWING IS THE SOLE PROPERTY OF EBSCO ANY REPRODUCTION IN PART OR AS A WHOLE WITHOUT THE WRITTEN PERMISSION OF EBSCO IS PROHIBITED.
 TOLERANCES PER RMA STANDARD A3
 REV. D
 DATE: 06-09-21
 UNITS: mm [INCH]
 1330 HOLMES RD. ELGIN, IL 60123

SPECIFICATIONS SUBJECT TO CHANGE