

2345

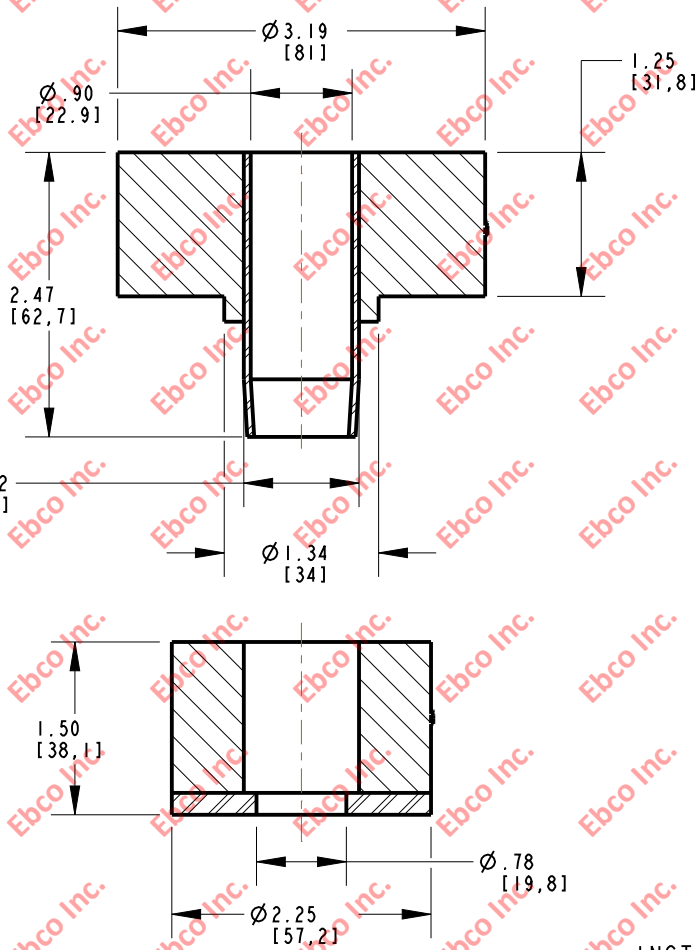

INSTALLATION VIEW (Shown under no load)

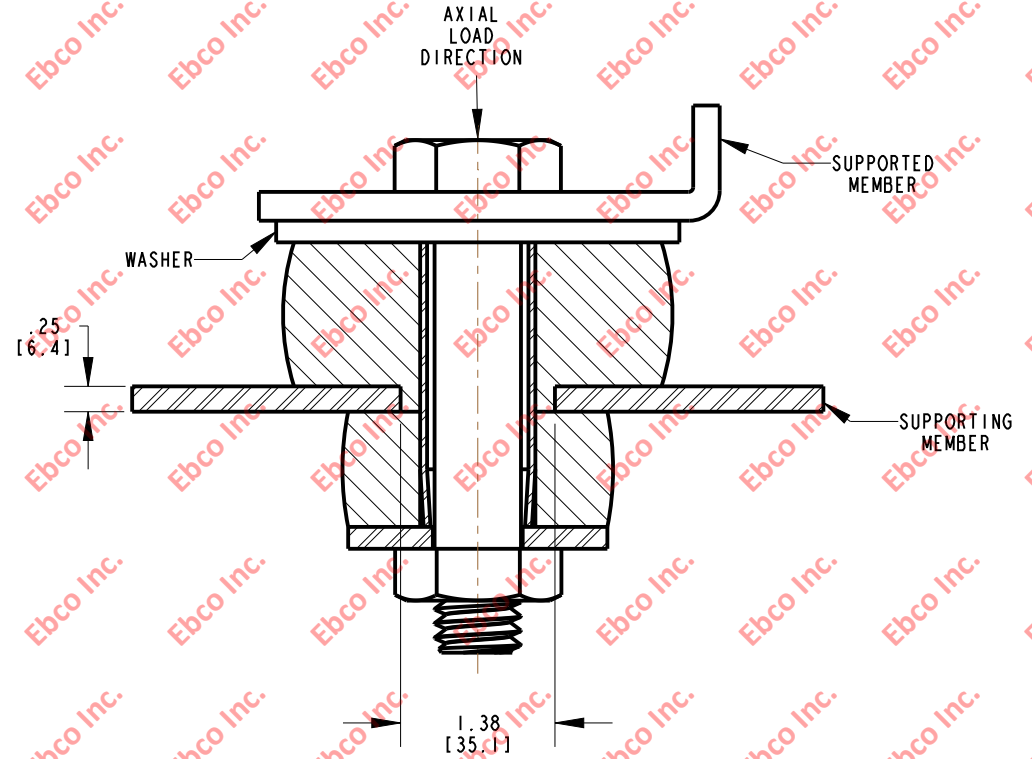

INSTALLATION DIMENSIONS

RECOMMENDED BOLT INFORMATION				TIGHTENING TORQUE			
ENGLISH		METRIC		CLAMP LOAD		TIGHTENING TORQUE	
SIZE	GRADE	SIZE	CLASS	lb	N	ft-lb	N-m
3/4	5	M18	9.8	21293	93600	266	337

WASHER SPECIFICATIONS

O. D.		I. D.		THICKNESS	
in	mm	in	mm	in	mm
3.50	88.90	.80	20.3	.188	4.78

SPECIFICATIONS

PART NUMBER		MAX. AXIAL DEFLECTION		MAX. AXIAL LOAD	
NATURAL RUBBER	NEOPRENE	in	mm	lb	N
2345-71	2345-81	.10	2.54	375	1668
2345-73	2345-83			650	2891
2345-75	2345-85			975	4339
2345-77	2345-87			1400	6228



TITLE: 2345
 THE INFORMATION CONTAINED IN THIS DRAWING IS THE SOLE PROPERTY OF EBCO ANY REPRODUCTION IN PART OR AS A WHOLE WITHOUT THE WRITTEN PERMISSION OF EBCO IS PROHIBITED.
 TOLERANCES PER RMA STANDARD A3
 REV. C
 DATE: 02-12-16
 UNITS INCH [MM]
 1330 HOLMES RD. ELGIN, IL 60123

SPECIFICATIONS SUBJECT TO CHANGE