

2344A

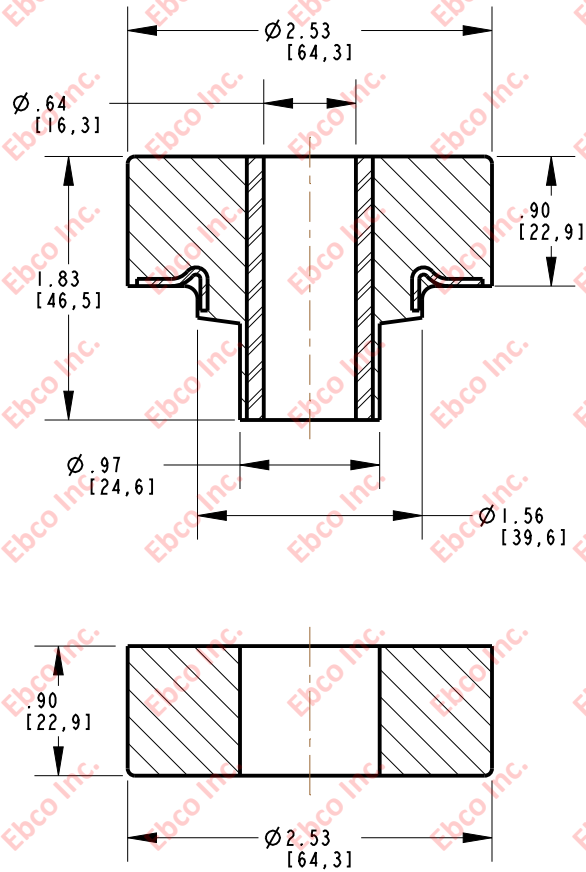

INSTALLATION VIEW (Shown under no load)

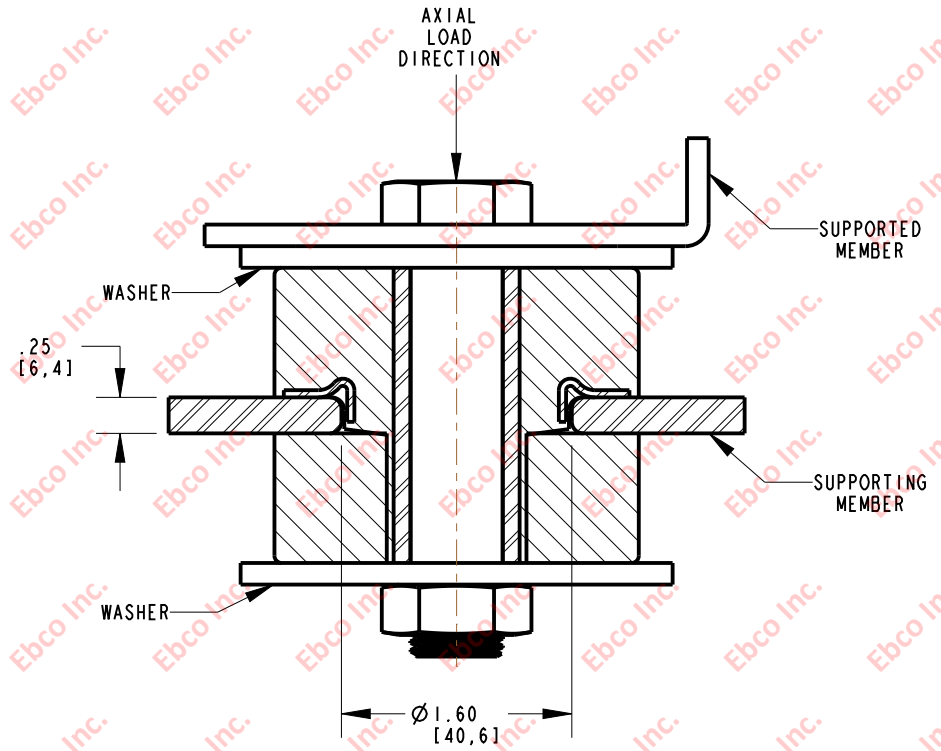

INSTALLATION DIMENSIONS

SPECIFICATIONS

PART NUMBER		MAX. AXIAL DEFLECTION		MAX. AXIAL LOAD	
NATURAL RUBBER	NEOPRENE	in	mm	lb	N
2344A-72	2344A-82	.09	2.29	440	1957
2344A-73	2344A-83			520	2314
2344A-74	2344A-84			615	2736
2344A-75	2344A-85			730	3248
2344A-76	2344A-86			870	3870

RECOMMENDED BOLT INFORMATION				TIGHTENING TORQUE			
ENGLISH		METRIC		CLAMP LOAD		TIGHTENING TORQUE	
SIZE	GRADE	SIZE	CLASS	lb	N	ft-lb	N-m
5/8	5	M16	9.8	14408	64090	150	203

WASHER SPECIFICATIONS

O. D.		I. D.		THICKNESS	
in	mm	in	mm	in	mm
2.81	71.37	.657	16.69	.188	4.78



TITLE: 2344A		
THE INFORMATION CONTAINED IN THIS DRAWING IS THE SOLE PROPERTY OF EBCO. ANY REPRODUCTION IN PART OR AS A WHOLE WITHOUT THE WRITTEN PERMISSION OF EBCO IS PROHIBITED.		
TOLERANCES PER RMA STANDARD A3	REV. B	DATE: 08-12-13 UNITS: INCH [MM]
1330 HOLMES RD. ELGIN, IL 60123		

SPECIFICATIONS SUBJECT TO CHANGE