

2340A

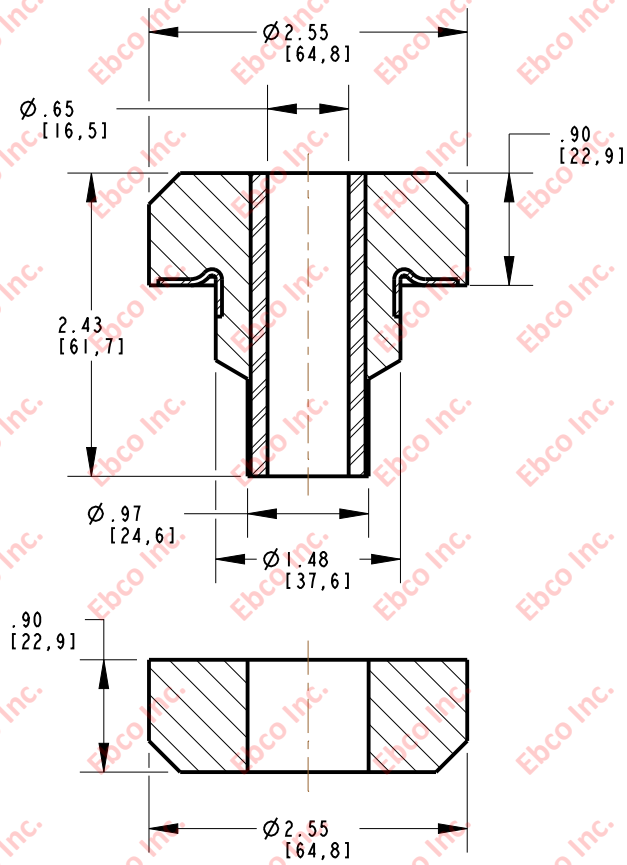

INSTALLATION VIEW (Shown under no load)

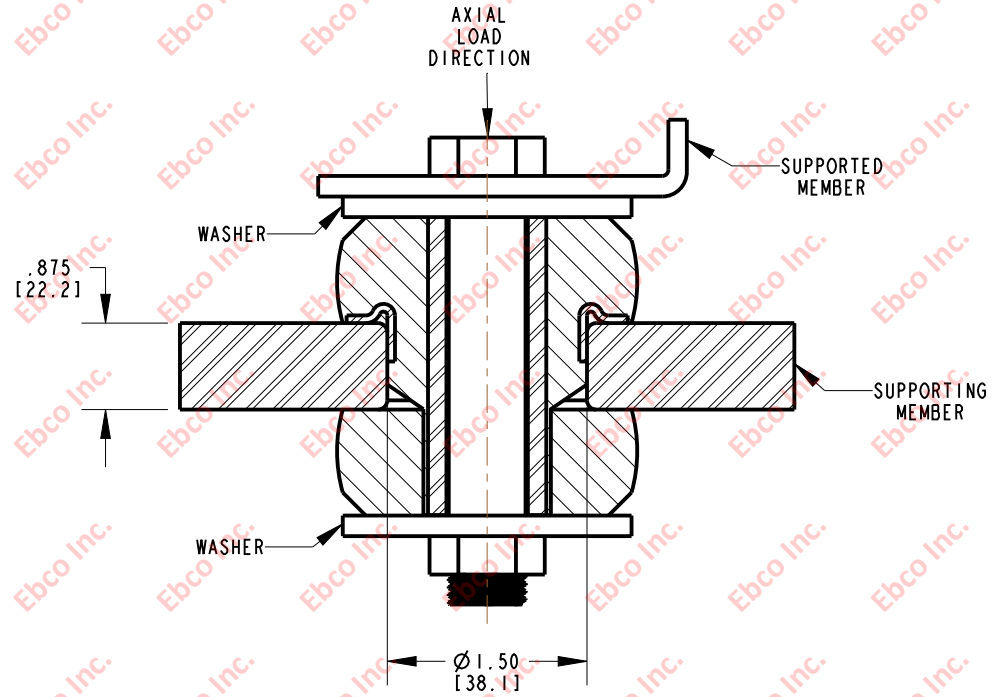

INSTALLATION DIMENSIONS

SPECIFICATIONS

PART NUMBER		MAX. AXIAL DEFLECTION		MAX. AXIAL LOAD	
NATURAL RUBBER	NEOPRENE	in	mm	lb	N
2340A-71	2340A-81	.09	2.29	350	1557
2340A-72	2340A-82			450	2003
2340A-73	2340A-83			600	2669
2340A-74	2340A-84			710	3160
2340A-75	2040A-85			825	3671
2340A-77	2340A-87			1400	6228

RECOMMENDED BOLT INFORMATION				TIGHTENING TORQUE			
ENGLISH		METRIC		CLAMP LOAD		TIGHTENING TORQUE	
SIZE	GRADE	SIZE	CLASS	lb	N	ft-lb	N-m
5/8	5	M16	9.8	14408	64090	150	203
WASHER SPECIFICATIONS							
O. D.		I. D.		THICKNESS			
in	mm	in	mm	in	mm		
2.81	71.37	.657	16.69	.188	4.78		



TITLE: 2340A	
THE INFORMATION CONTAINED IN THIS DRAWING IS THE SOLE PROPERTY OF EBCU. ANY REPRODUCTION IN PART OR AS A WHOLE WITHOUT THE WRITTEN PERMISSION OF EBCU IS PROHIBITED.	
TOLERANCES PER RMA STANDARD A3	REV. B
DATE: 08-12-13	UNITS: INCH [MM]
1330 HOLMES RD. ELGIN, IL 60123	

SPECIFICATIONS SUBJECT TO CHANGE