

2333A

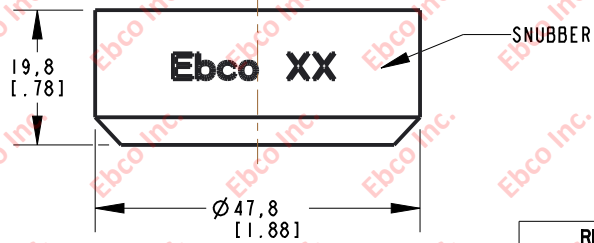

INSTALLATION VIEW (Shown under no load)

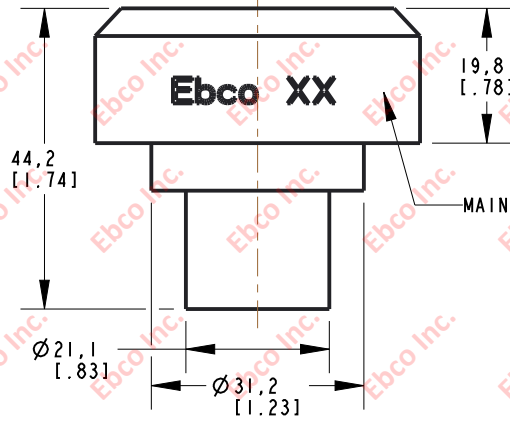
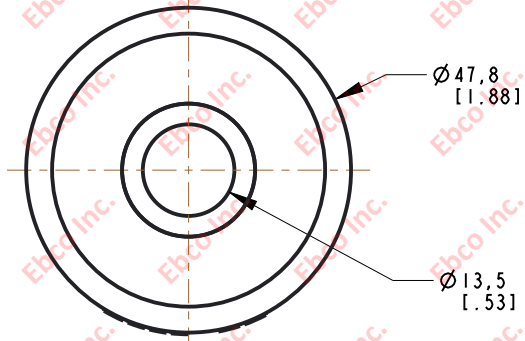
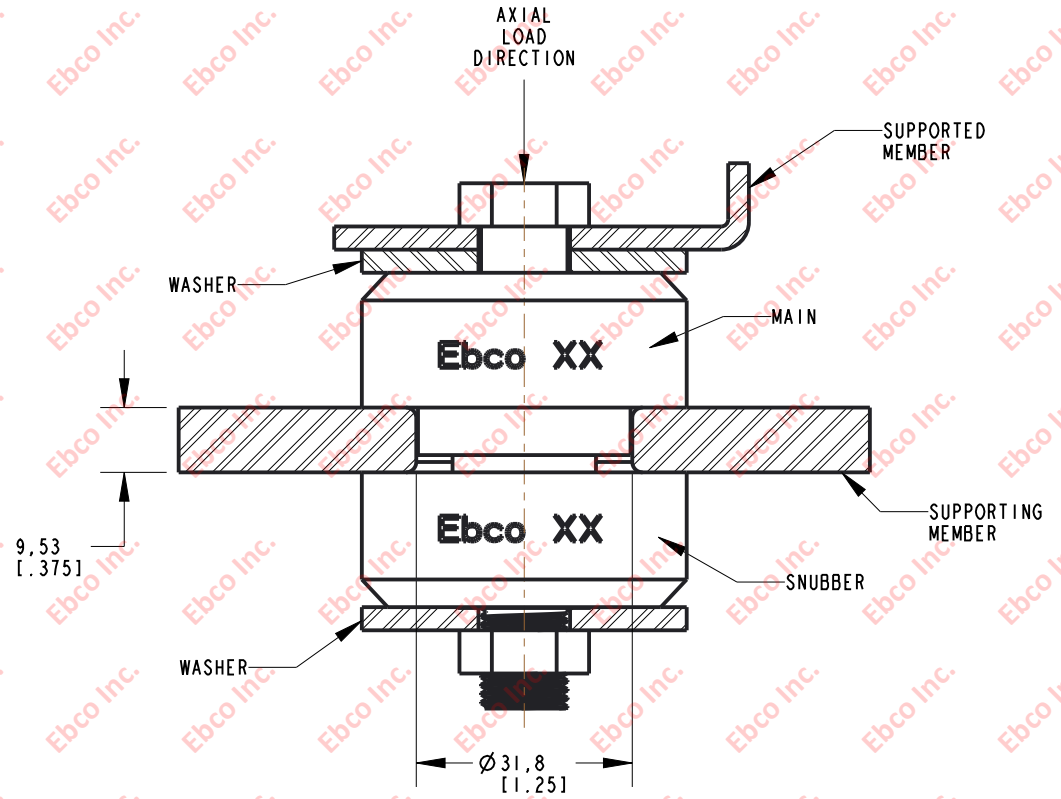

INSTALLATION DIMENSIONS

RECOMMENDED BOLT INFORMATION				TIGHTENING TORQUE			
ENGLISH		METRIC		CLAMP LOAD		TIGHTENING TORQUE	
SIZE	GRADE	SIZE	CLASS	lb	N	ft-lb	N-m
1/2	5	M12	9.8	9046	40239	75.4	101.8
WASHER SPECIFICATIONS							
O.D.		I.D.		THICKNESS			
in	mm	in	mm	in	mm		
2.13	54.10	.53	13.46	.134	3.40		

SPECIFICATIONS

PART NUMBER		MAX. AXIAL DEFLECTION		MAX. AXIAL LOAD	
NATURAL RUBBER	NEOPRENE	in	mm	lb	N
2333A-70	2333A-80	.07	1.78	160	712
2333A-71	2333A-81			190	845
2333A-73	2333A-83			260	1157



TITLE: 2333A	
THE INFORMATION CONTAINED IN THIS DRAWING IS THE SOLE PROPERTY OF EBCO ANY REPRODUCTION IN PART OR AS A WHOLE WITHOUT THE WRITTEN PERMISSION OF EBCO IS PROHIBITED.	
TOLERANCES PER RMA STANDARD A3	REV. D
DATE: 07-19-21	UNITS: mm [INCH]
1330 HOLMES RD. ELGIN, IL 60123	
SPECIFICATIONS SUBJECT TO CHANGE	