

2331

DWG. NO.

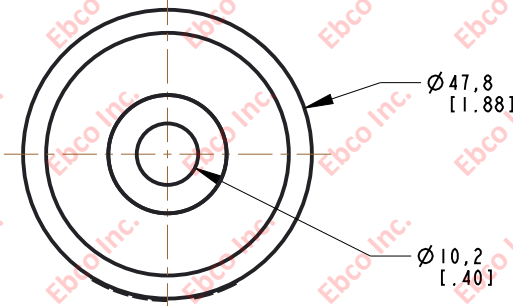

INSTALLATION VIEW (Shown under no load)

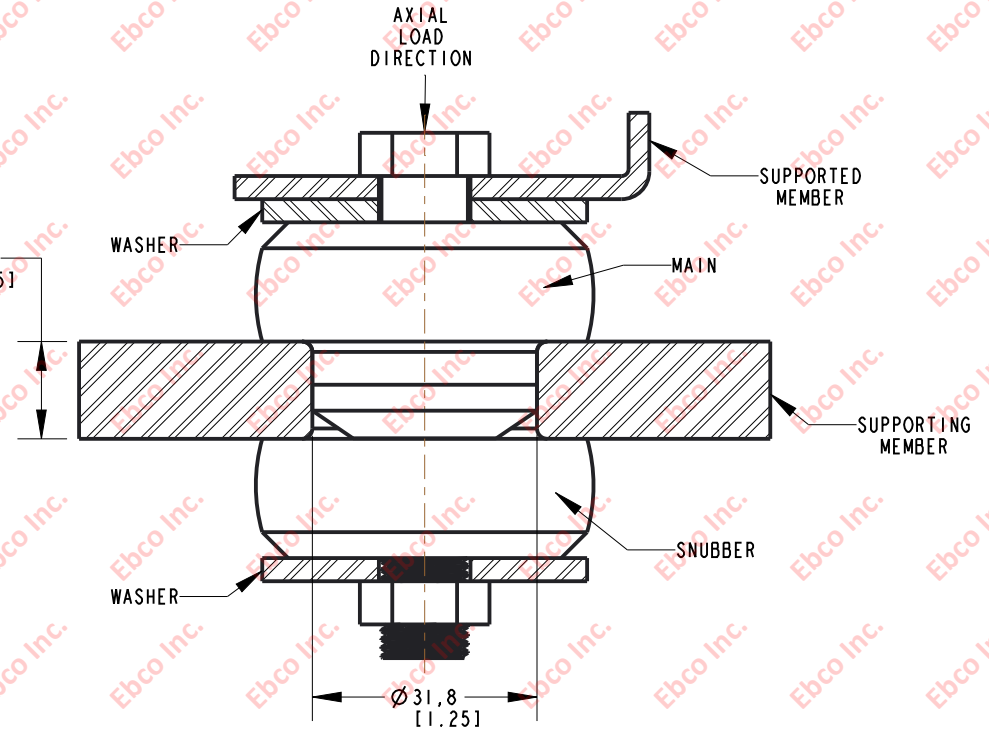
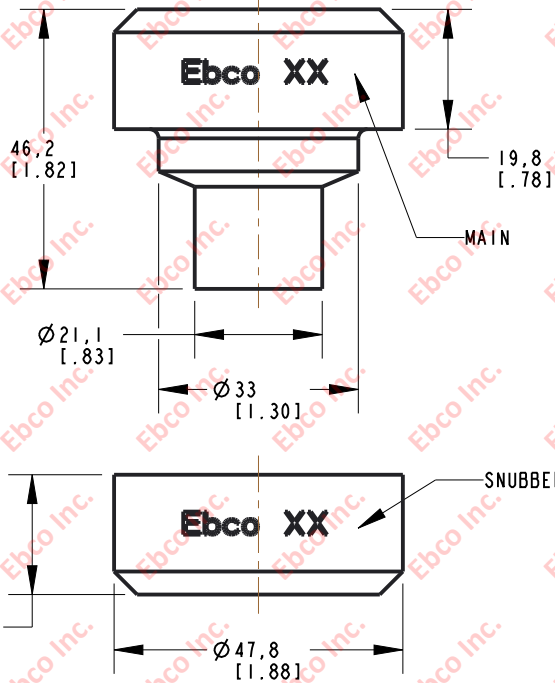

INSTALLATION DIMENSIONS

SPECIFICATIONS

PART NUMBER		MAX. AXIAL DEFLECTION		MAX. AXIAL LOAD	
NATURAL RUBBER	NEOPRENE	in	mm	lb	N
2331-70	2331-80	.07	1.78	80	356
2331-71	2331-81			100	445
2331-73	2331-83			140	623
2331-74	2331-84			170	757
2331-75	2331-85			210	934
2331-76	2331-86			260	1157
2331-77	2331-87			350	1557

RECOMMENDED BOLT INFORMATION				TIGHTENING TORQUE			
ENGLISH		METRIC		CLAMP LOAD		TIGHTENING TORQUE	
SIZE	GRADE	SIZE	CLASS	lb	N	ft-lb	N-m
3/8	5	M10	9.8	4941	21979	30.9	41.72
WASHER SPECIFICATIONS							
O. D.		I. D.		THICKNESS			
in	mm	in	mm	in	mm		
2.13	54.10	.40	10.16	.134	3.40		



TITLE: 2331

THE INFORMATION CONTAINED IN THIS DRAWING IS THE SOLE PROPERTY OF EBCU ANY REPRODUCTION IN PART OR AS A WHOLE WITHOUT THE WRITTEN PERMISSION OF EBCU IS PROHIBITED.

TOLERANCES PER RMA STANDARD A3

REV. C

DATE: 06-09-21

UNITS: mm [INCH]

1330 HOLMES RD. ELGIN, IL 60123

SPECIFICATIONS SUBJECT TO CHANGE