

2300

DWG. NO.

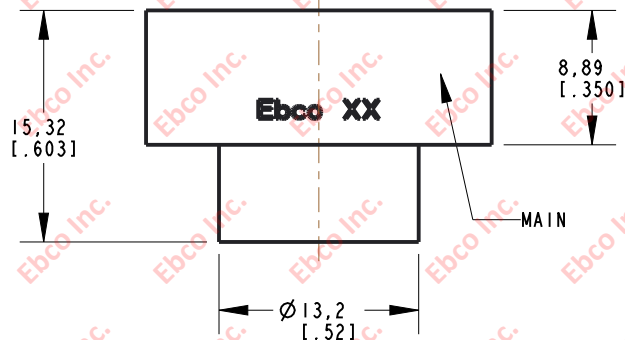

INSTALLATION VIEW (Shown under no load)

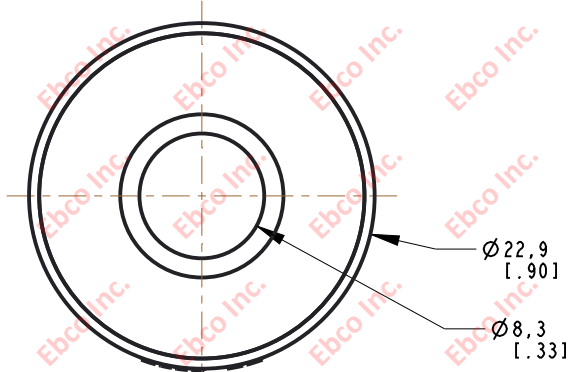
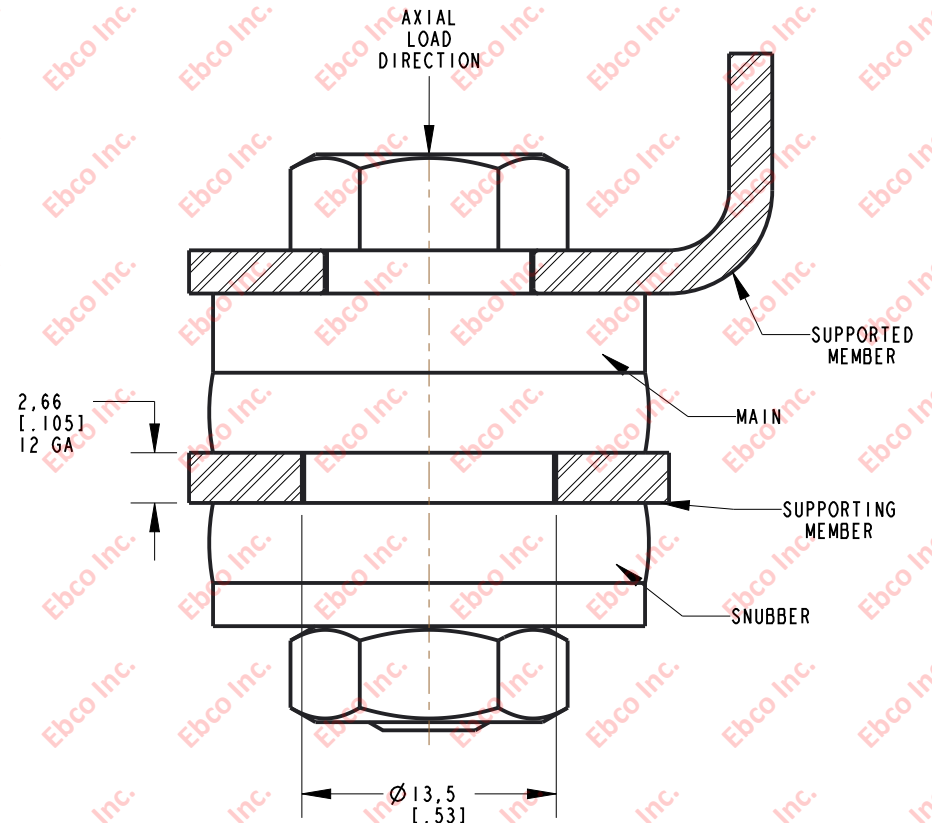

PERFORMANCE SPECIFICATIONS

PART NUMBER			MAX. AXIAL DEFLECTION		MAX. AXIAL LOAD	
NATURAL RUBBER	NEOPRENE	NITRILE	in	mm	lb	N
2300-72	2300-82	2300-52	0.005	0.13	13	71

INSTALLATION SPECIFICATIONS

RECOMMENDED BOLT INFORMATION				TIGHTENING TORQUE			
ENGLISH		METRIC		CLAMP LOAD		TIGHTENING TORQUE	
SIZE	GRADE	SIZE	CLASS	lb	N	ft-lb	N-m
5/16	5	M8	9.8	3341	17.4	17.8	28.55



TITLE:	2300	
THE INFORMATION CONTAINED IN THIS DRAWING IS THE SOLE PROPERTY OF EBCO ANY REPRODUCTION IN PART OR AS A WHOLE WITHOUT THE WRITTEN PERMISSION OF EBCO IS PROHIBITED.		
TOLERANCES PER RMA STANDARD A3	REV. D	DATE: 07-19-21
		UNITS mm [ INCH ]
1330 HOLMES RD. ELGIN, IL 60123		
SPECIFICATIONS SUBJECT TO CHANGE		