

2283

DWG. NO.

B

A

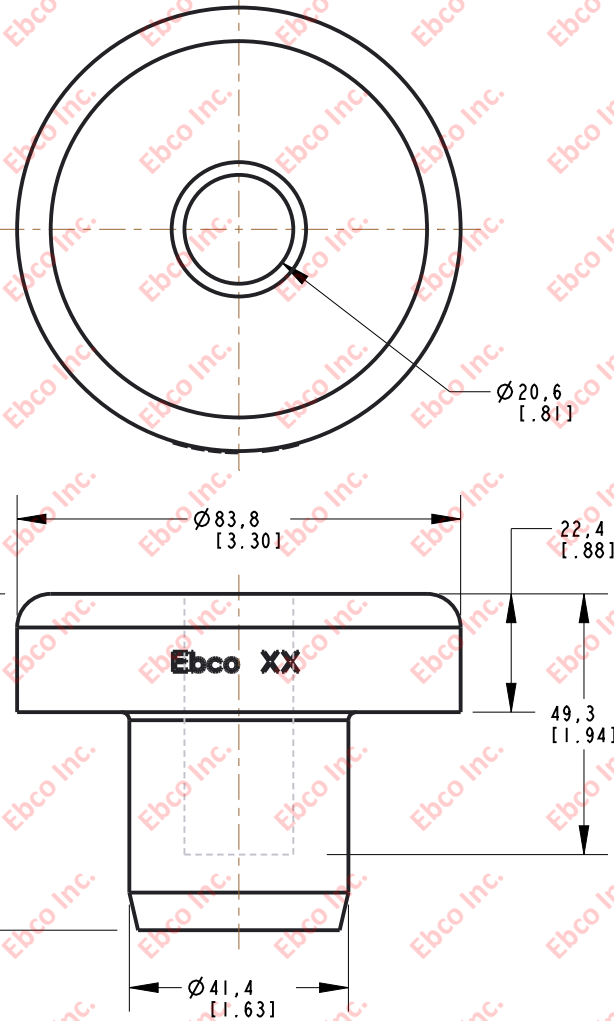

INSTALLATION VIEW (Shown under no load)

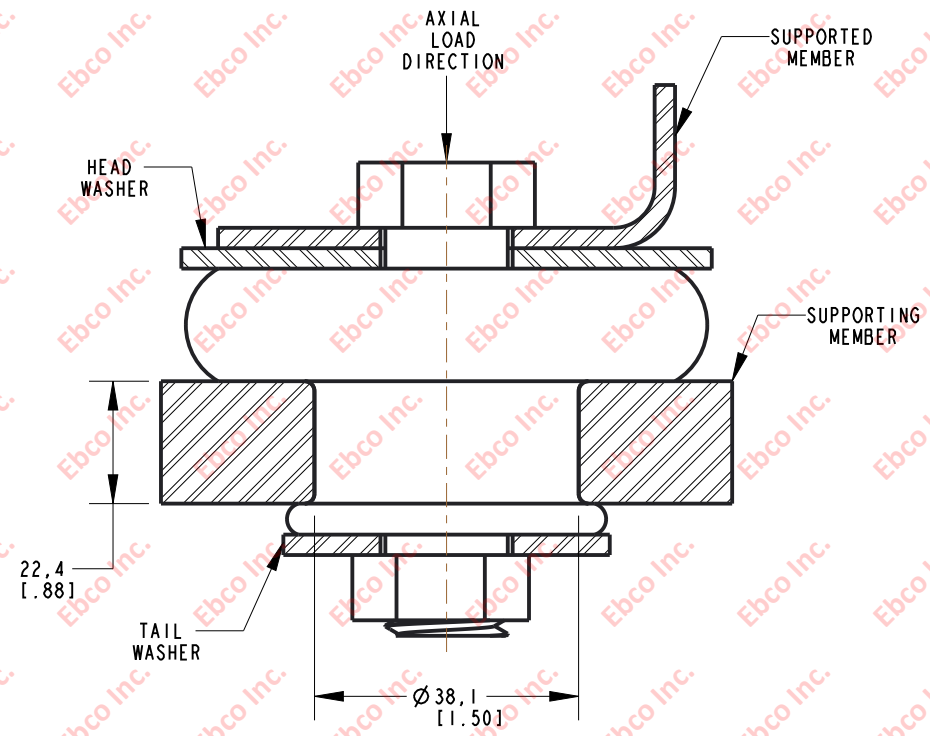

INSTALLATION DIMENSIONS

SPECIFICATIONS

PART NUMBER		MAX. AXIAL DEFLECTION		MAX. AXIAL LOAD	
NATURAL RUBBER	NEOPRENE	in	mm	lb	N
2283-71	2283-81	.12	3.05	700	3114
2283-72	2283-82			850	3781
2283-73	2283-83			1000	4448
2283-74	2283-84			1200	5340
2283-75	2283-85			1550	6895
2283-76	2283-86			1950	8674
2283-77	2283-87			2400	10676

RECOMMENDED BOLT INFORMATION				TIGHTENING TORQUE			
ENGLISH		METRIC		CLAMP LOAD		TIGHTENING TORQUE	
SIZE	GRADE	SIZE	CLASS	lb	N	ft-lb	N-m
3/4	5	M18	9.8	21293	93600	266	430
WASHER SPECIFICATIONS							
TYPE	O.D.		I.D.		THICKNESS		
	in	mm	in	mm	in	mm	
HEAD	3.88	98.55	.80	20.32	.19	4.83	
TAIL	2.75	69.85	.80	20.32			



TITLE:	2283		
THE INFORMATION CONTAINED IN THIS DRAWING IS THE SOLE PROPERTY OF EBCO ANY REPRODUCTION IN PART OR AS A WHOLE WITHOUT THE WRITTEN PERMISSION OF EBCO IS PROHIBITED.			
TOLERANCES PER RMA STANDARD	REV. E	DATE: 06-08-21	UNITS: mm [INCH]
A3			
1330 HOLMES RD. ELGIN, IL 60123			
SPECIFICATIONS SUBJECT TO CHANGE			