

2252

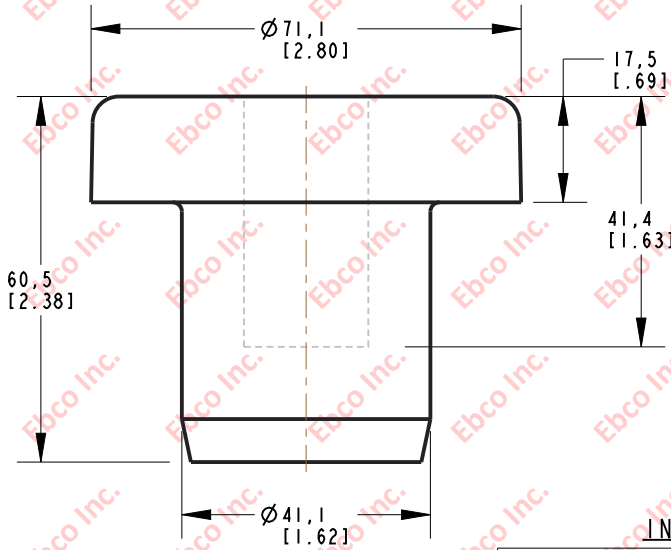

INSTALLATION VIEW (Shown under no load)

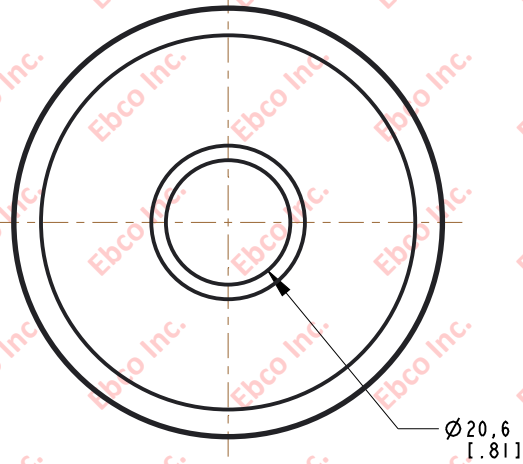
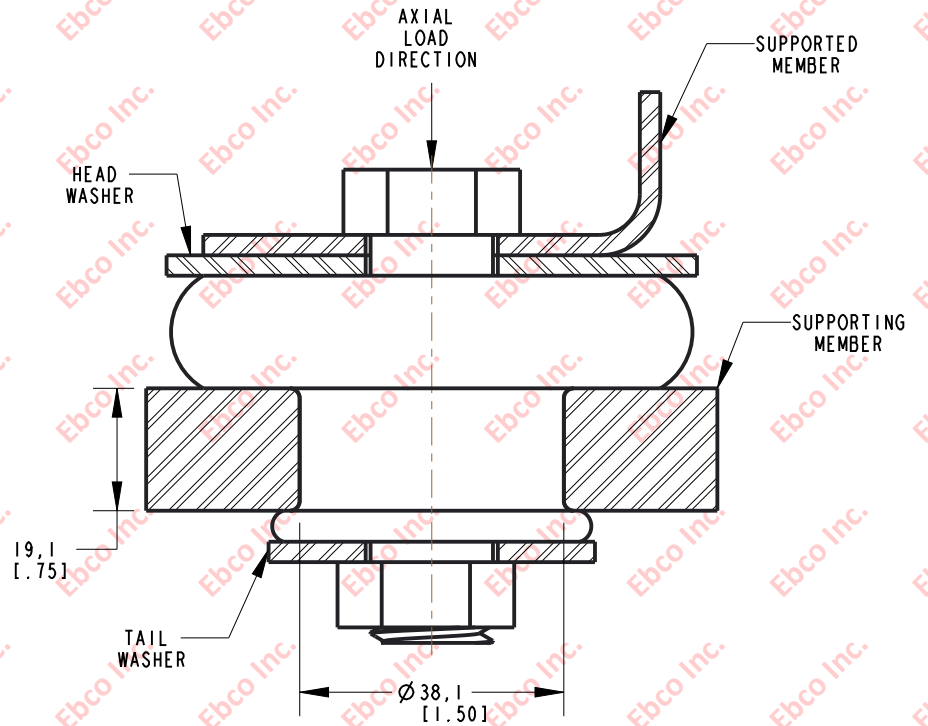

INSTALLATION DIMENSIONS

SPECIFICATIONS

PART NUMBER		MAX. AXIAL DEFLECTION		MAX. AXIAL LOAD	
NATURAL RUBBER	NEOPRENE	in	mm	lb	N
2252-72	2252-82	.10	2.54	750	3336
2252-73	2252-83			850	3781
2252-74	2252-84			950	4226
2252-75	2252-85			1050	4671
2252-77	2252-87			1500	6672

RECOMMENDED BOLT INFORMATION				TIGHTENING TORQUE			
ENGLISH		METRIC		CLAMP LOAD		TIGHTENING TORQUE	
SIZE	GRADE	SIZE	CLASS	lb	N	ft-lb	N-m
3/4	5	M18	9.8	21293	94716	266	359
WASHER SPECIFICATIONS							
TYPE	O. D.		I. D.		THICKNESS		
	in	mm	in	mm	in	mm	
HEAD	3.25	82.55	.80	20.32	.188	4.78	
TAIL	2.50	63.50	.80	20.32			



TITLE:	2252
THE INFORMATION CONTAINED IN THIS DRAWING IS THE SOLE PROPERTY OF EBCO ANY REPRODUCTION IN PART OR AS A WHOLE WITHOUT THE WRITTEN PERMISSION OF EBCO IS PROHIBITED.	
TOLERANCES PER RMA STANDARD A3	REV. C
DATE: 06-08-21	UNITS: mm [INCH]
1330 HOLMES RD. ELGIN, IL 60123	

SPECIFICATIONS SUBJECT TO CHANGE