

2250

IMP. NO.

INSTALLATION VIEW (Shown under no load)

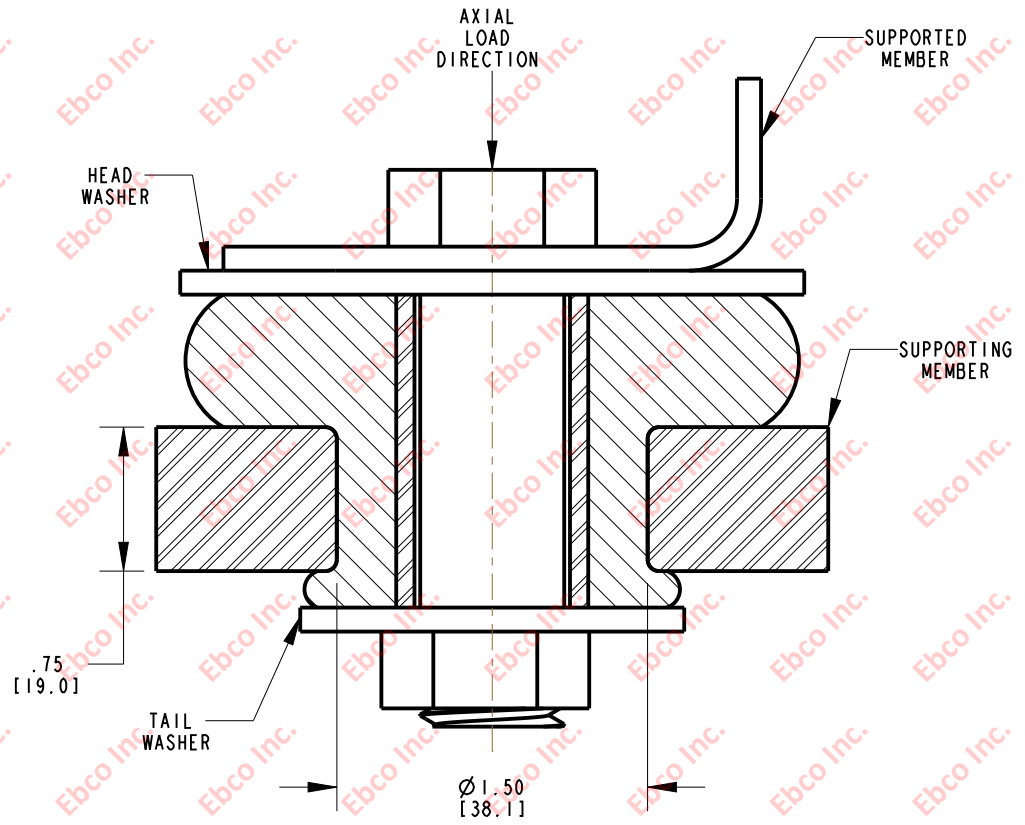
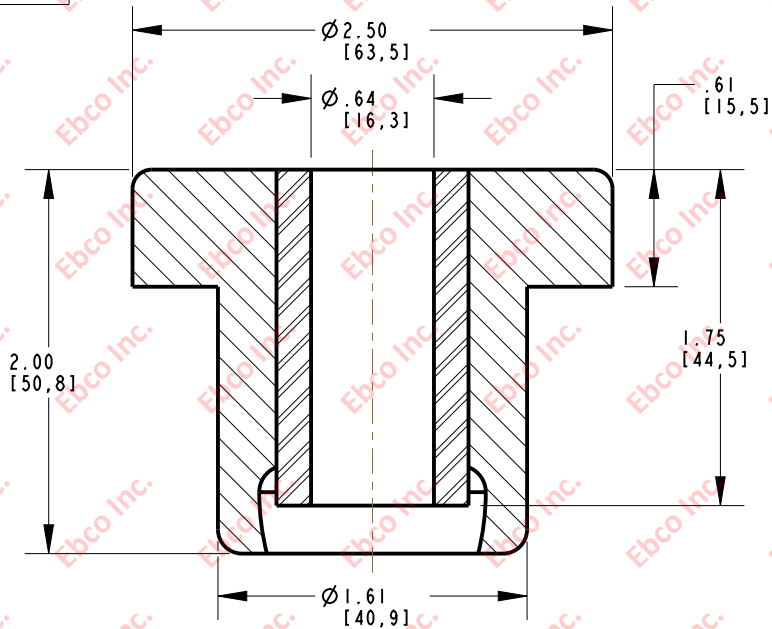

INSTALLATION DIMENSIONS

RECOMMENDED BOLT INFORMATION				TIGHTENING TORQUE			
ENGLISH		METRIC		CLAMP LOAD		TIGHTENING TORQUE	
SIZE	GRADE	SIZE	CLASS	lb	N	ft-lb	N-m
5/8	5	M16	9.8	14408	64090	150	203

WASHER SPECIFICATIONS						
TYPE	O.D.		I.D.		THICKNESS	
	in	mm	in	mm	in	mm
HEAD	2.88	73.15	.64	16.26	.125	3.18
TAIL	2.25	57.15	.64	16.26		

SPECIFICATIONS

PART NUMBER		MAX. AXIAL DEFLECTION		MAX. AXIAL LOAD	
NATURAL RUBBER	NEOPRENE	in	mm	lb	N
2250-75	2250-85	.07	1.78	450	2002
2250-77	2250-87			850	3781
2250-79	2250-89			1200	5338



TITLE: 2250
 THE INFORMATION CONTAINED IN THIS DRAWING IS THE SOLE PROPERTY OF EBCO ANY REPRODUCTION IN PART OR AS A WHOLE WITHOUT THE WRITTEN PERMISSION OF EBCO IS PROHIBITED.
 TOLERANCES PER RMA STANDARD A3
 REV. B
 DATE: 08-12-13
 UNITS: INCH [MM]
 1330 HOLMES RD. ELGIN, IL 60123

SPECIFICATIONS SUBJECT TO CHANGE