

2240A

IMP. NO.

B

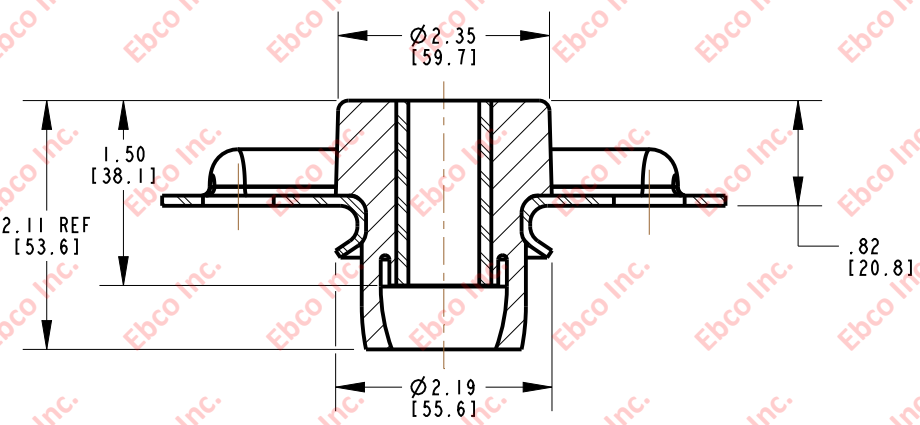
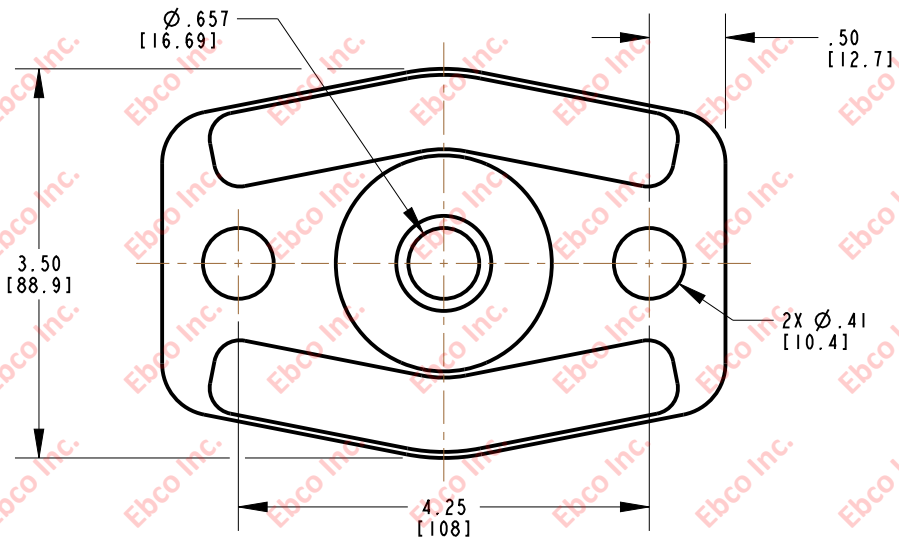

INSTALLATION VIEW (Shown under no load)

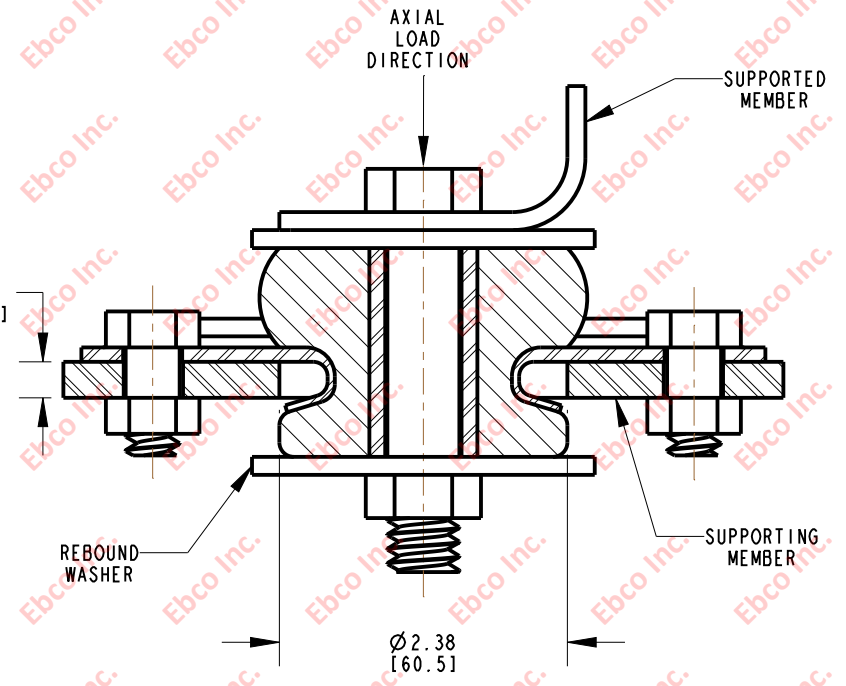

INSTALLATION DIMENSIONS

RECOMMENDED BOLT INFORMATION				TIGHTENING TORQUE			
ENGLISH		METRIC		CLAMP LOAD		TIGHTENING TORQUE	
SIZE	GRADE	SIZE	CLASS	lb	N	ft-lb	N-m
5/8	5	M16	9.8	14408	64090	150	203

WASHER SPECIFICATIONS					
O. D.		I. D.		THICKNESS	
in	mm	in	mm	in	mm
2.88	73.15	.66	16.76	.125	3.18

SPECIFICATIONS

PART NUMBER		MAX. AXIAL DEFLECTION		MAX. AXIAL LOAD	
NATURAL RUBBER	NEOPRENE	in	mm	lb	N
2240A-74	2240A-84	.12	3.05	510	2269
2240A-75	2240A-85			655	2915



TITLE: 2240A		
THE INFORMATION CONTAINED IN THIS DRAWING IS THE SOLE PROPERTY OF EBCO. ANY REPRODUCTION IN PART OR AS A WHOLE WITHOUT THE WRITTEN PERMISSION OF EBCO IS PROHIBITED.		
TOLERANCES PER RMA STANDARD A3	REV. D	DATE: 11-04-14 UNITS: INCH [MM]
1330 HOLMES RD. ELGIN, IL 60123		

SPECIFICATIONS SUBJECT TO CHANGE