

2220

IMP. NO.

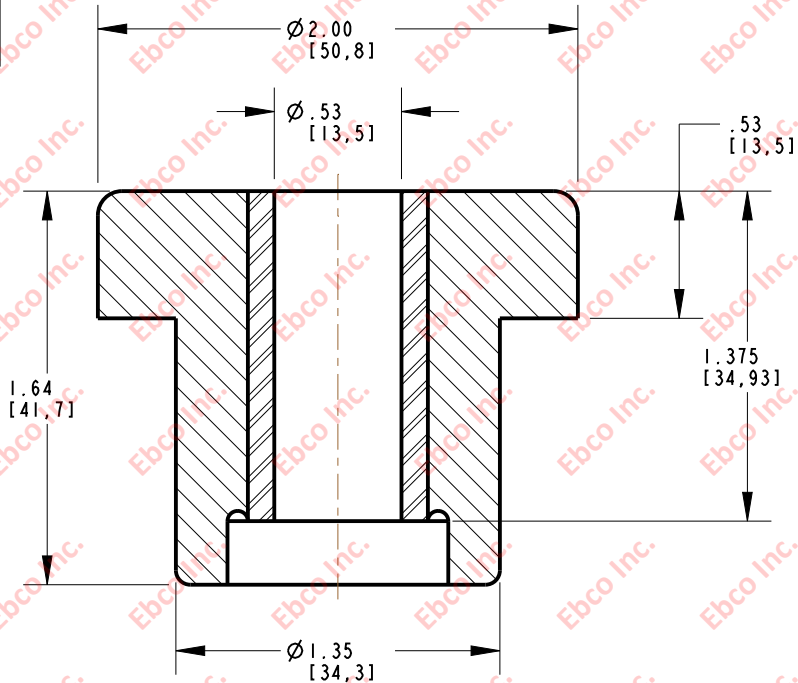

INSTALLATION VIEW (Shown under no load)

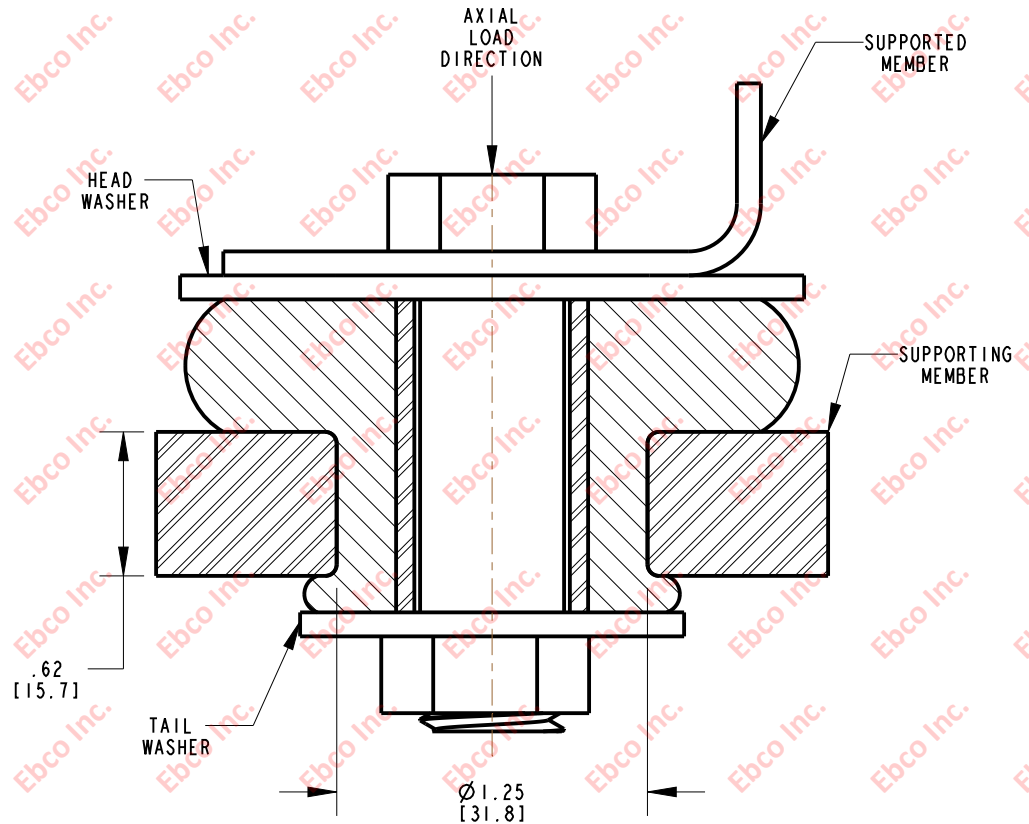

INSTALLATION DIMENSIONS

RECOMMENDED BOLT INFORMATION				TIGHTENING TORQUE			
ENGLISH		METRIC		CLAMP LOAD		TIGHTENING TORQUE	
SIZE	GRADE	SIZE	CLASS	lb	N	ft-lb	N-m
1/2	5	M12	9.8	9046	40239	75.4	101.8

WASHER SPECIFICATIONS

TYPE	O.D.		I.D.		THICKNESS	
	in	mm	in	mm	in	mm
HEAD	2.25	57.15	.52	13.21	.125	3.18
TAIL	2.00	50.80	.52	13.21		

SPECIFICATIONS

PART NUMBER		MAX. AXIAL DEFLECTION		MAX. AXIAL LOAD	
NATURAL RUBBER	NEOPRENE	in	mm	lb	N
2220-73	2220-83	.06	1.52	240	1068
2220-74	2220-84			300	1334
2220-75	2220-85			360	1602



TITLE: 2220  
 THE INFORMATION CONTAINED IN THIS DRAWING IS THE SOLE PROPERTY OF EBCO. ANY REPRODUCTION IN PART OR AS A WHOLE WITHOUT THE WRITTEN PERMISSION OF EBCO IS PROHIBITED.  
 TOLERANCES PER RMA STANDARD A3  
 REV. C  
 DATE: 08-12-13  
 UNITS: INCH [MM]  
 1330 HOLMES RD. ELGIN, IL 60123

SPECIFICATIONS SUBJECT TO CHANGE