

2170

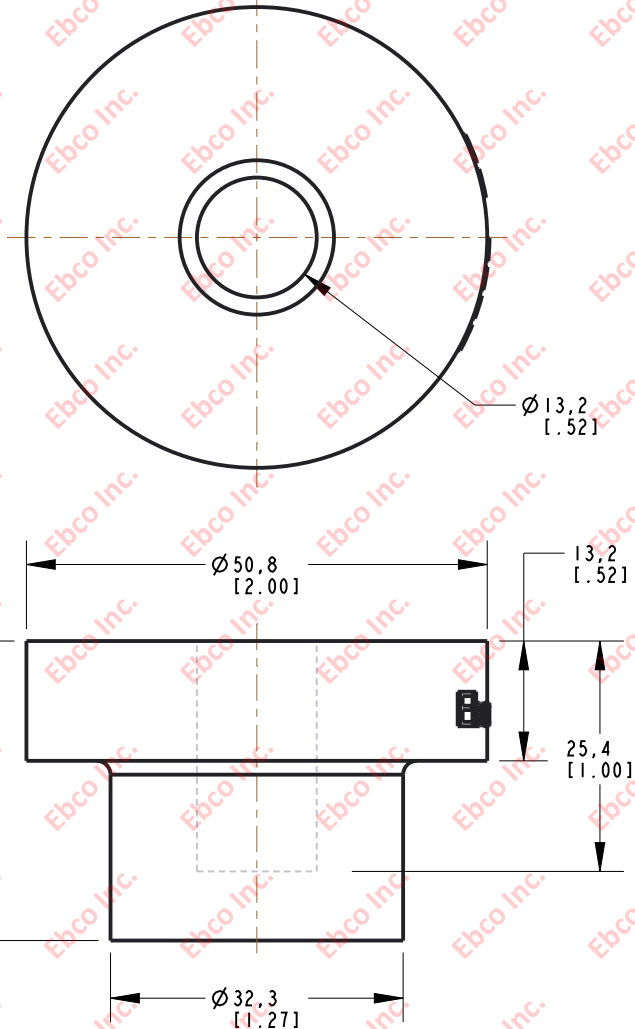

INSTALLATION VIEW (Shown under no load)

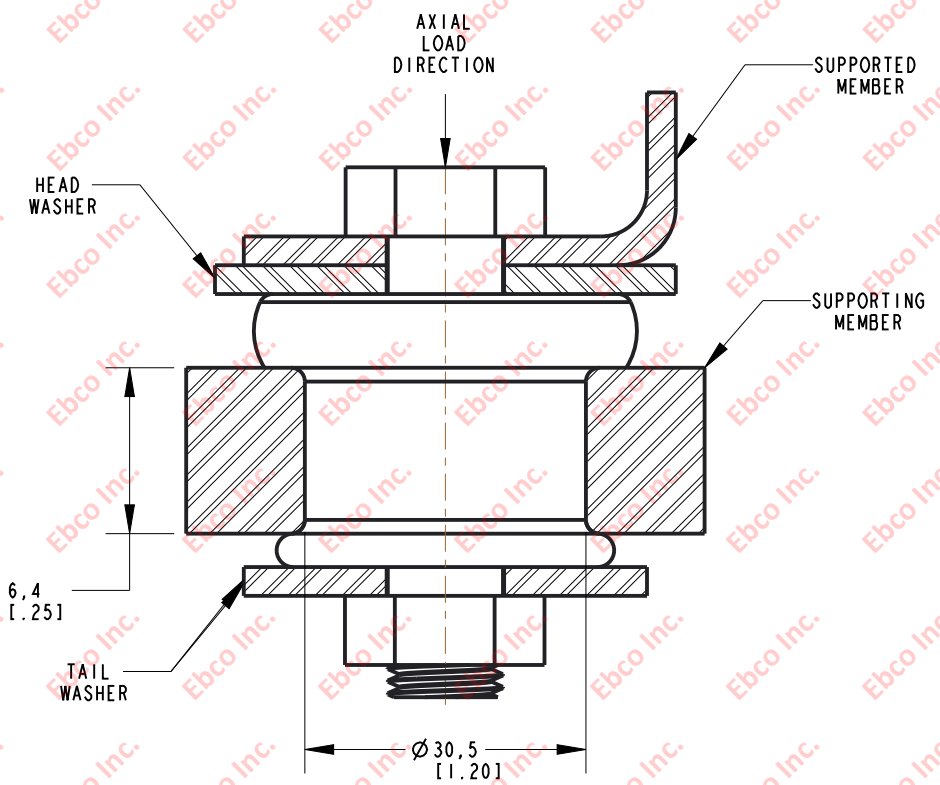

INSTALLATION DIMENSIONS

RECOMMENDED BOLT INFORMATION				TIGHTENING TORQUE			
ENGLISH		METRIC		CLAMP LOAD		TIGHTENING TORQUE	
SIZE	GRADE	SIZE	CLASS	lb	N	ft-lb	N-m
1/2	5	M12	9.8	9046	40239	75.4	101.8

WASHER SPECIFICATIONS

TYPE	O.D.		I.D.		THICKNESS	
	in	mm	in	mm	in	mm
HEAD	2.50	2.50	.52	13.21	.125	3.18
TAIL	1.75	44.45	.52	13.21		

SPECIFICATIONS

PART NUMBER		MAX. AXIAL DEFLECTION		MAX. AXIAL LOAD	
NATURAL RUBBER	NEOPRENE	in	mm	lb	N
2170-71	2170-81	.05	1.27	200	890
2170-73	2170-83			325	1446
2170-76	2170-86			450	2002



TITLE: 2170  
 THE INFORMATION CONTAINED IN THIS DRAWING IS THE SOLE PROPERTY OF EBCO ANY REPRODUCTION IN PART OR AS A WHOLE WITHOUT THE WRITTEN PERMISSION OF EBCO IS PROHIBITED.  
 TOLERANCES PER RMA STANDARD A3  
 REV. C  
 DATE: 06-08-21  
 UNITS: mm [INCH]  
 1330 HOLMES RD. ELGIN, IL 60123  
 SPECIFICATIONS SUBJECT TO CHANGE