

2130

DRG. NO.

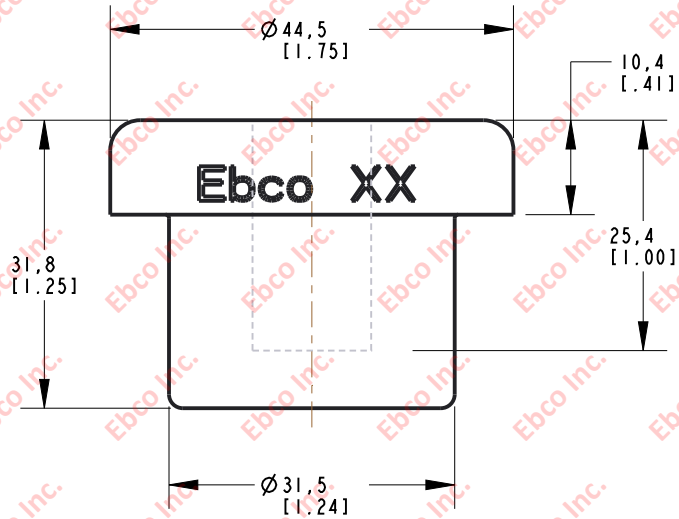

INSTALLATION VIEW (Shown under no load)

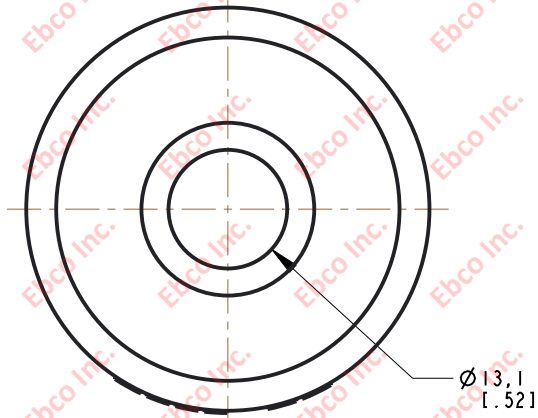
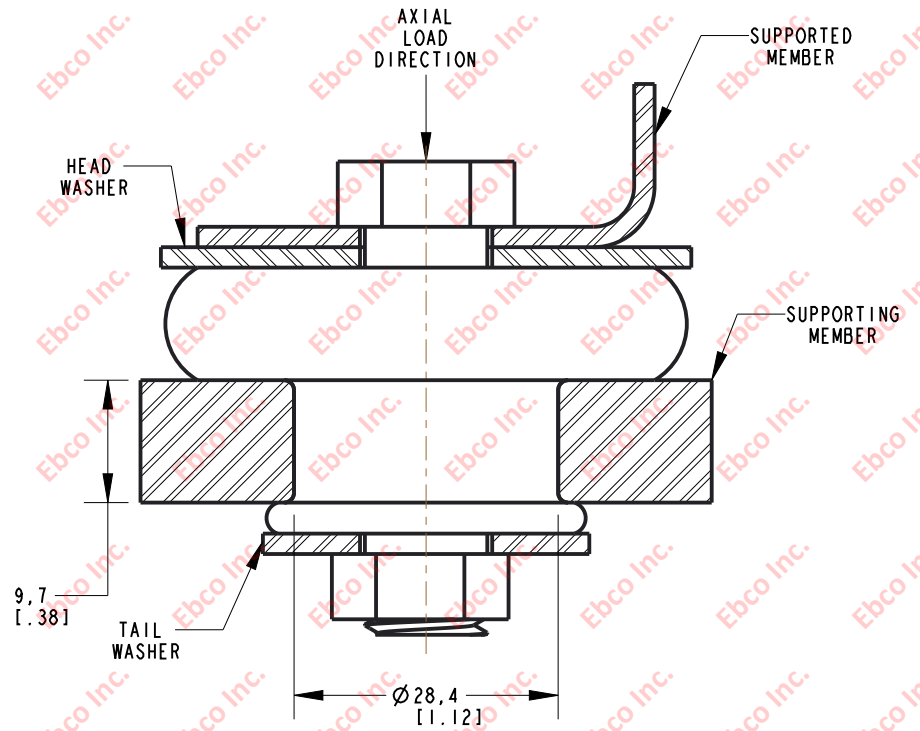

INSTALLATION DIMENSIONS

SPECIFICATIONS

PART NUMBER		MAX. AXIAL DEFLECTION		MAX. AXIAL LOAD	
NATURAL RUBBER	NEOPRENE	in	mm	lb	N
2130-71	2130-81	.04	1.02	90	400
2130-72	2130-82			130	578
2130-73	2130-83			175	778
2130-74	2130-84			250	1112
2130-76	2130-86			290	1290

RECOMMENDED BOLT INFORMATION				TIGHTENING TORQUE			
ENGLISH		METRIC		CLAMP LOAD		TIGHTENING TORQUE	
SIZE	GRADE	SIZE	CLASS	lb	N	ft-lb	N-m
1/2	5	M12	9.8	9046	40238	75.4	101.8
WASHER SPECIFICATIONS							
TYPE	O.D.		I.D.		THICKNESS		
	in	mm	in	mm	in	mm	
HEAD	2.00	50.80	.52	13.21	.125	3.18	
TAIL	1.50	38.10	.52	13.21			



TITLE:	2130
THE INFORMATION CONTAINED IN THIS DRAWING IS THE SOLE PROPERTY OF EBCU. ANY REPRODUCTION IN PART OR AS A WHOLE WITHOUT THE WRITTEN PERMISSION OF EBCU IS PROHIBITED.	
TOLERANCES PER RMA STANDARD	REV. D
A3	DATE: 06-08-21
	UNITS: mm [INCH]
1330 HOLMES RD. ELGIN, IL 60123	

SPECIFICATIONS SUBJECT TO CHANGE