

2120

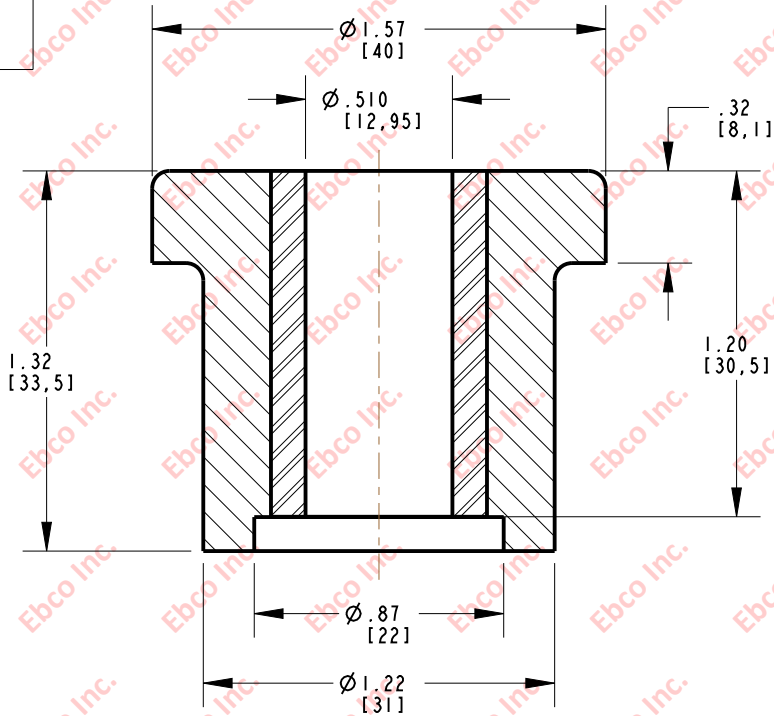

INSTALLATION VIEW (Shown under no load)

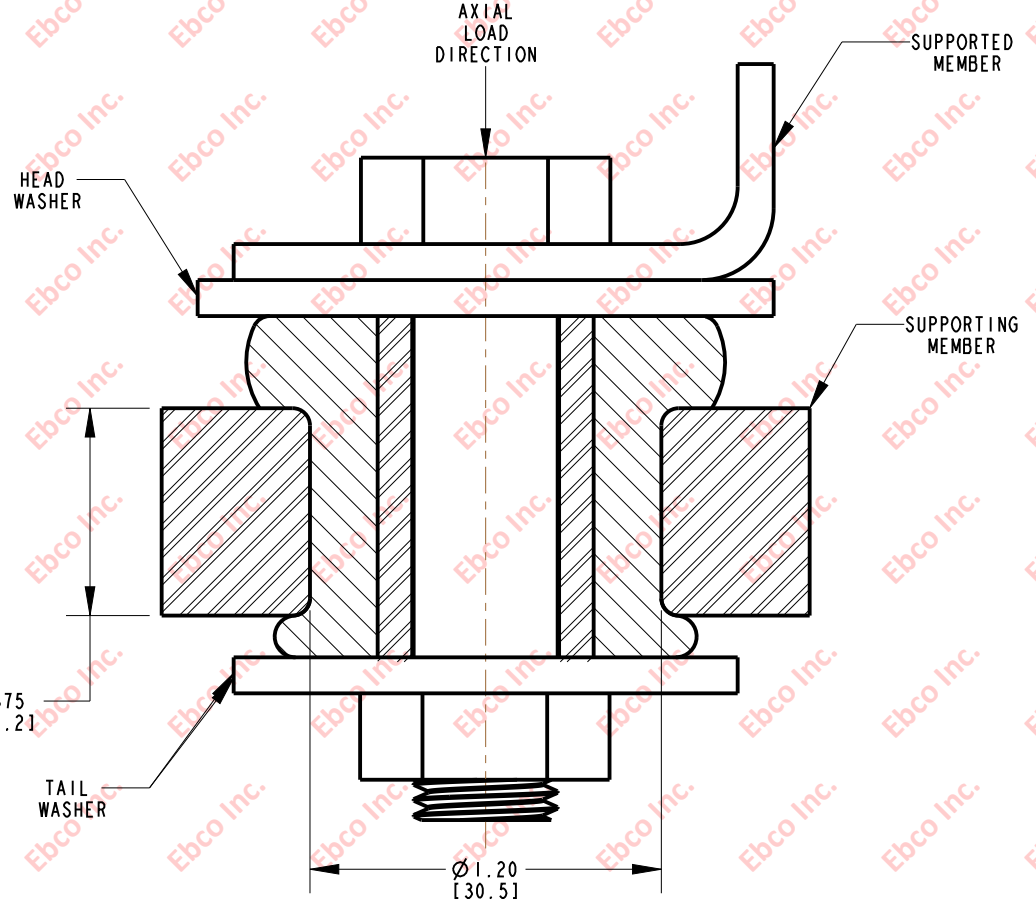

INSTALLATION DIMENSIONS

RECOMMENDED BOLT INFORMATION				TIGHTENING TORQUE			
ENGLISH		METRIC		CLAMP LOAD		TIGHTENING TORQUE	
SIZE	GRADE	SIZE	CLASS	lb	N	ft-lb	N-m
1/2	5	M12	9.8	9046	40239	75.4	101.8
WASHER SPECIFICATIONS							
TYPE	O.D.		I.D.		THICKNESS		
	in	mm	in	mm	in	mm	
HEAD	2.00	50.80	.52	13.21	125	3.18	
TAIL	1.50	38.10	.52	13.21			

SPECIFICATIONS

PART NUMBER		MAX. AXIAL DEFLECTION		MAX. AXIAL LOAD	
NATURAL RUBBER	NEOPRENE	in	mm	lb	N
2120-75	2120-85	.03	.76	550	912
2120-76	2120-86			650	2448
2120-77	2120-87			750	3336
2120-78	2120-88			850	3783



TITLE:	2120		
THE INFORMATION CONTAINED IN THIS DRAWING IS THE SOLE PROPERTY OF EBCO. ANY REPRODUCTION IN PART OR AS A WHOLE WITHOUT THE WRITTEN PERMISSION OF EBCO IS PROHIBITED.			
TOLERANCES PER RMA STANDARD	REV. C	DATE: 09-15-16	UNITS: [INCH] [MM]
A3			
1330 HOLMES RD. ELGIN, IL 60123			

SPECIFICATIONS SUBJECT TO CHANGE