

2118

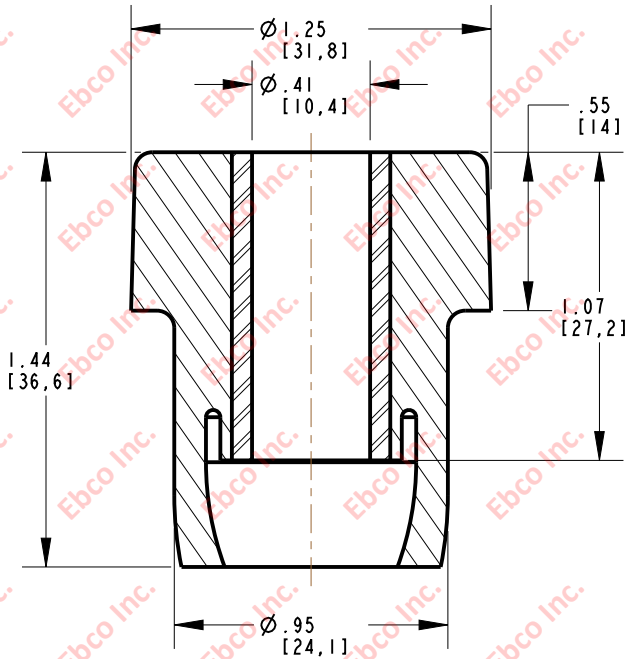

INSTALLATION VIEW (Shown under no load)

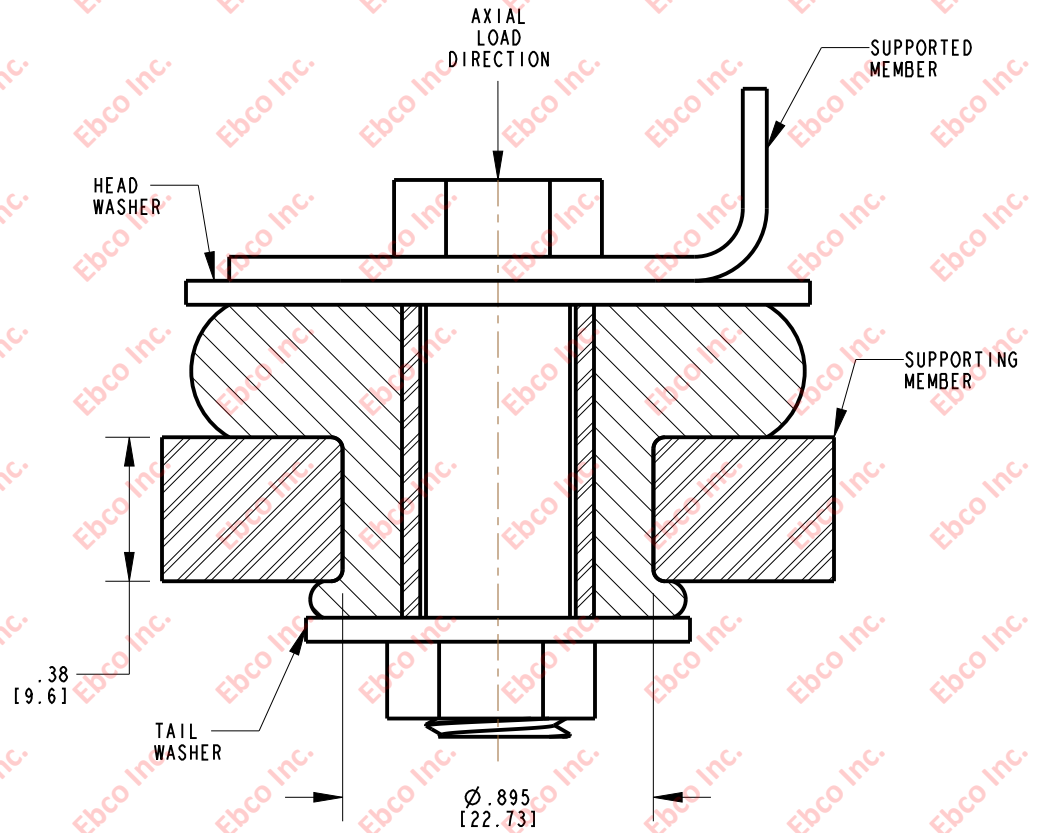

INSTALLATION DIMENSIONS

RECOMMENDED BOLT INFORMATION				TIGHTENING TORQUE			
ENGLISH		METRIC		CLAMP LOAD		TIGHTENING TORQUE	
SIZE	GRADE	SIZE	CLASS	lb	N	ft-lb	N-m
3/8	5	M10	9.8	4941	21979	30.9	41.7
WASHER SPECIFICATIONS							
TYPE	O.D.		I.D.		THICKNESS		
	in	mm	in	mm	in	mm	
HEAD	1.50	38.10	.42	10.67	.12	3.05	
TAIL	1.25	31.75	.42	10.67			

SPECIFICATIONS

PART NUMBER		MAX. AXIAL DEFLECTION		MAX. AXIAL LOAD	
NATURAL RUBBER	NEOPRENE	in	mm	lb	N
2118-71	2118-81	.09	2.29	100	445
2118-74	2118-84			150	667
2118-75	2118-85			175	778
2118-76	2118-86			210	890
2118-77	2118-87			250	1112



TITLE: 2118	
THE INFORMATION CONTAINED IN THIS DRAWING IS THE SOLE PROPERTY OF EBCO. ANY REPRODUCTION IN PART OR AS A WHOLE WITHOUT THE WRITTEN PERMISSION OF EBCO IS PROHIBITED.	
TOLERANCES PER RMA STANDARD A3	REV. C
DATE: 03-13-14	UNITS: INCH [MM]
1330 HOLMES RD. ELGIN, IL 60123	

SPECIFICATIONS SUBJECT TO CHANGE