

2115

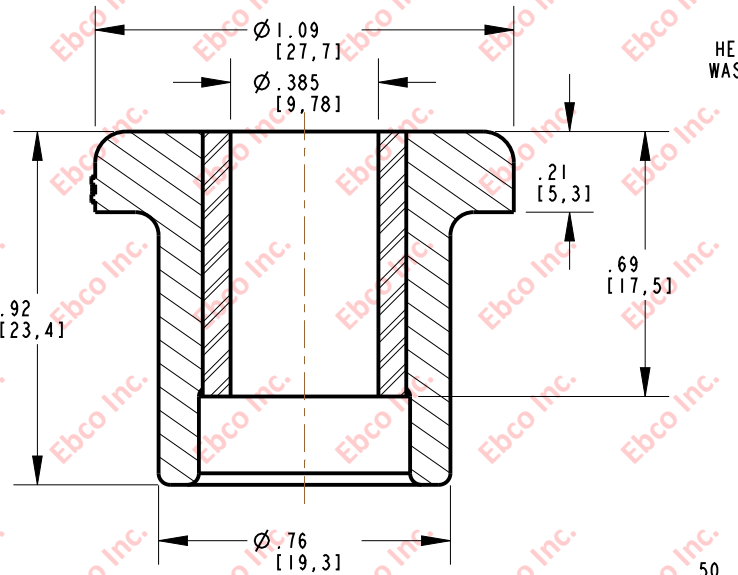

INSTALLATION VIEW (Shown under no load)

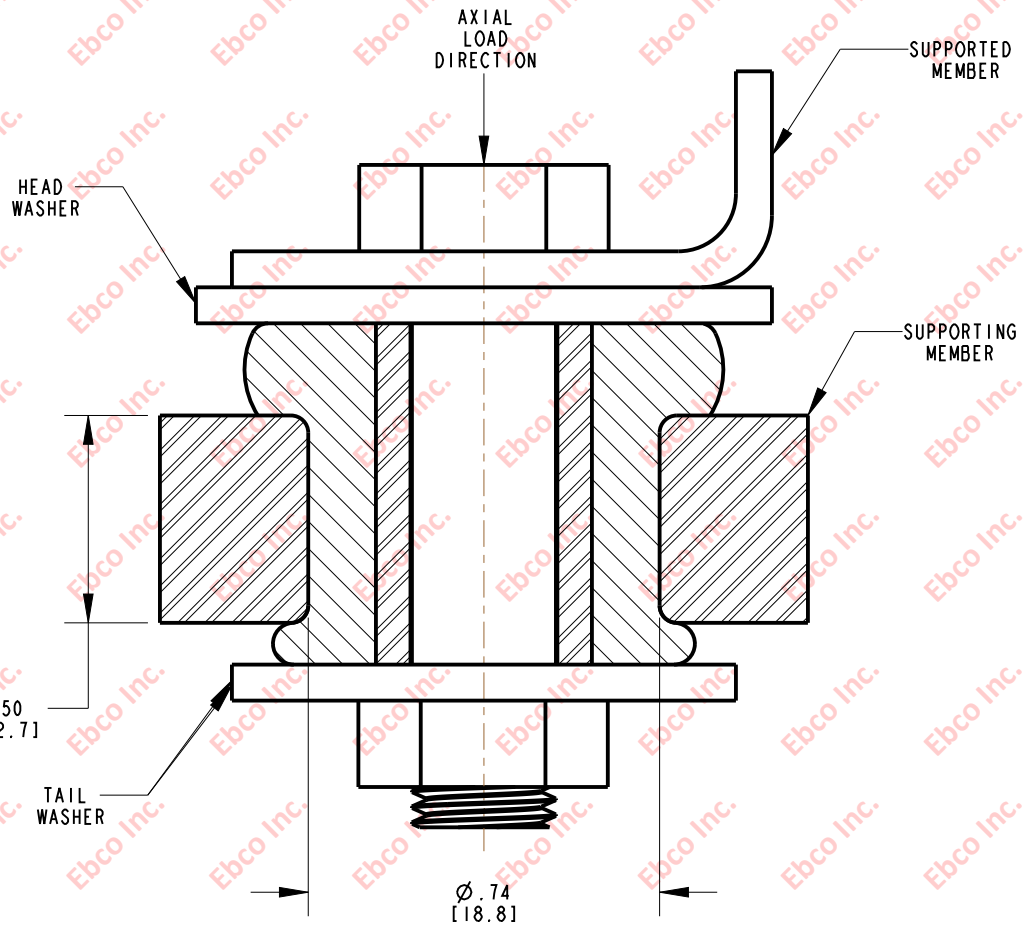

INSTALLATION DIMENSIONS

RECOMMENDED BOLT INFORMATION				TIGHTENING TORQUE			
ENGLISH		METRIC		CLAMP LOAD		TIGHTENING TORQUE	
SIZE	GRADE	SIZE	CLASS	lb	N	ft-lb	N-m
3/8	2	M8	5.8	3197	10400	20.0	16.7

WASHER SPECIFICATIONS

TYPE	O. D.		I. D.		THICKNESS	
	in	mm	in	mm	in	mm
HEAD	1.25	31.75	.40	10.16	.125	3.18
TAIL	1.12	28.45	.40	10.16		

SPECIFICATIONS

PART NUMBER	DUROMETER (SHORE A)
EPDM	±5
2115-65	60



TITLE:	2115
THE INFORMATION CONTAINED IN THIS DRAWING IS THE SOLE PROPERTY OF EBSCO ANY REPRODUCTION IN PART OR AS A WHOLE WITHOUT THE WRITER PERMISSION OF EBSCO IS PROHIBITED.	
TOLERANCES PER RMA STANDARD A3	REV. E
DATE: 07-16-20	UNITS: INCH [MM]

1330 HOLMES RD. ELGIN, IL 60123

SPECIFICATIONS SUBJECT TO CHANGE