

2115

DWG. NO.

INSTALLATION VIEW (Shown under no load)

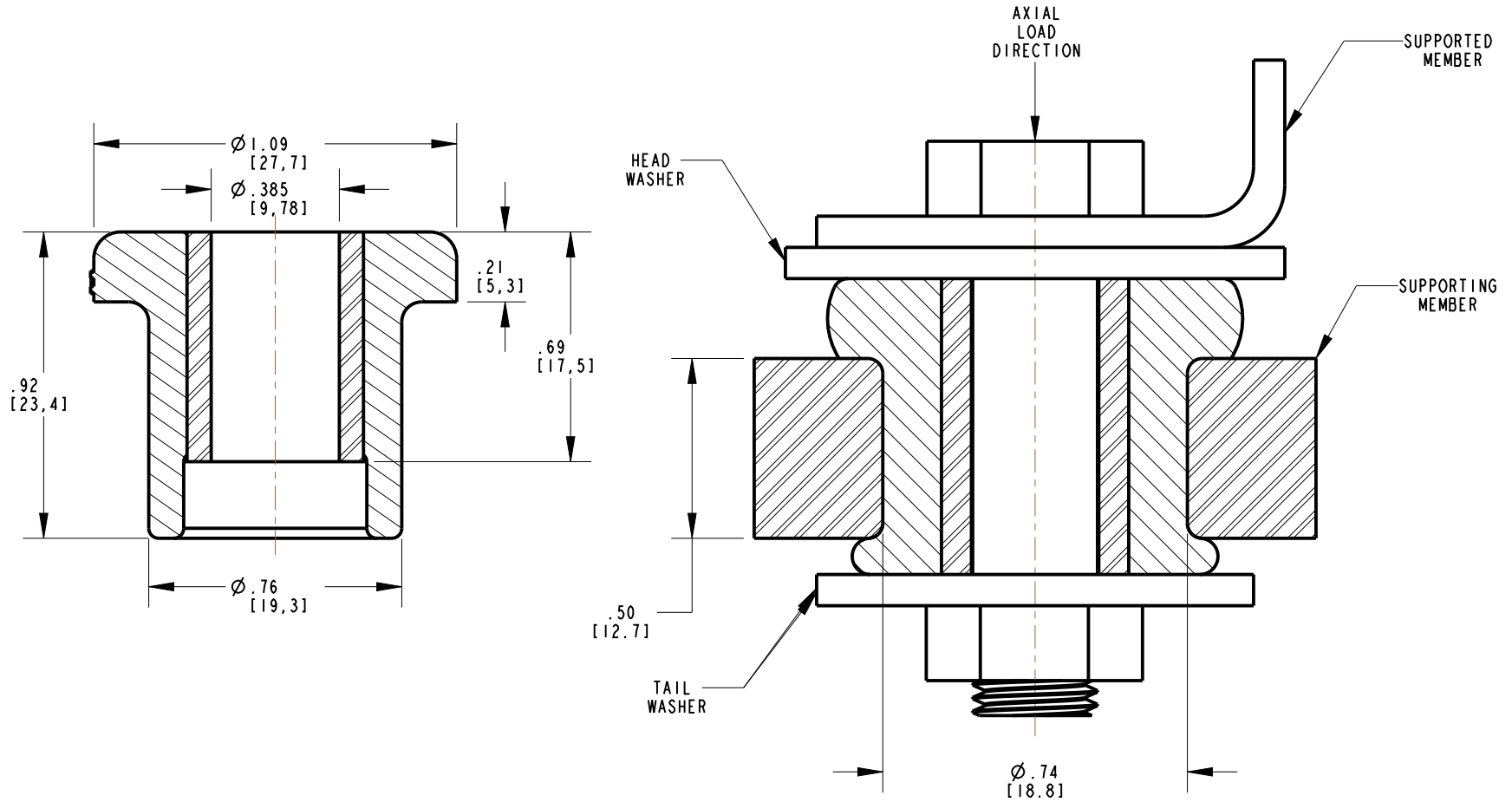

INSTALLATION DIMENSIONS

RECOMMENDED BOLT INFORMATION				TIGHTENING TORQUE			
ENGLISH		METRIC		CLAMP LOAD		TIGHTENING TORQUE	
SIZE	GRADE	SIZE	CLASS	lb	N	ft-lb	N-m
3/8	2	M8	5.8	3197	10400	20.0	16.7

WASHER SPECIFICATIONS						
TYPE	O. D.		I. D.		THICKNESS	
	in	mm	in	mm	in	mm
HEAD	1.25	31.75	.40	10.16	.125	3.18
TAIL	1.12	28.45	.40	10.16		

*AVAILABLE IN A VARIETY OF MATERIALS AND STIFFNESS



TITLE: 2115

THE INFORMATION CONTAINED IN THIS DRAWING IS THE SOLE PROPERTY OF EBCU ANY REPRODUCTION IN PART OR AS A WHOLE WITHOUT THE WRITTEN PERMISSION OF EBCU IS PROHIBITED.

TOLERANCES PER RMA STANDARD A3	REV. D	DATE: 11-03-16
		UNITS: INCH [MM]

1330 HOLMES RD. ELGIN, IL 60123

SPECIFICATIONS SUBJECT TO CHANGE