

2104

IMP. NO.

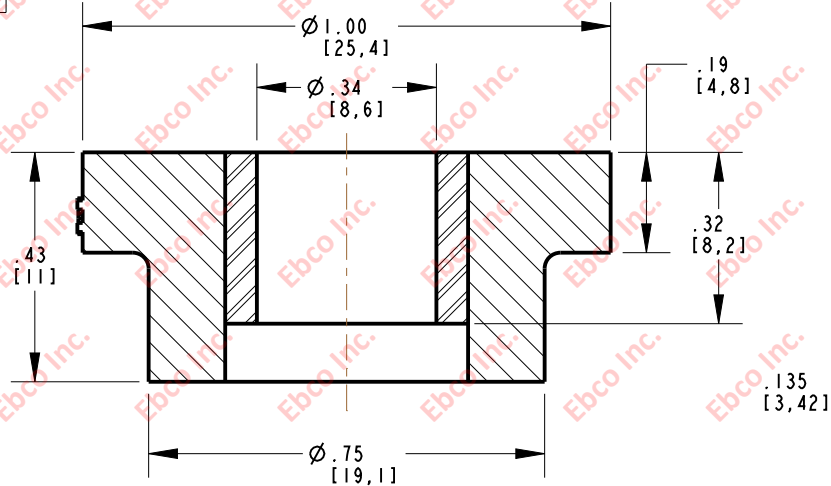

INSTALLATION VIEW (Shown under no load)

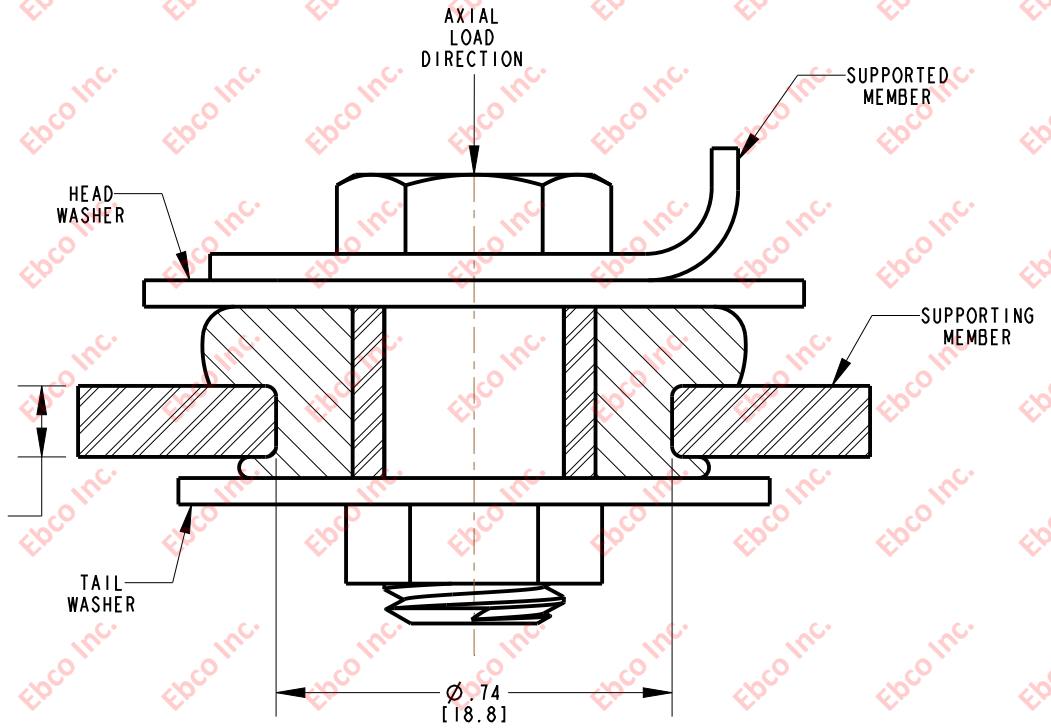

INSTALLATION DIMENSIONS

RECOMMENDED BOLT INFORMATION				TIGHTENING TORQUE			
ENGLISH		METRIC		CLAMP LOAD		TIGHTENING TORQUE	
SIZE	GRADE	SIZE	CLASS	lb	N	ft-lb	N-m
5/16	5	M6	5.8	3338	14848	17	23

WASHER SPECIFICATIONS						
TYPE	O.D.		I.D.		THICKNESS	
	in	mm	in	mm	in	mm
HEAD	1.25	31.75	.40	10.16	.125	3.18
TAIL	1.12	28.45	.40	10.16		

SPECIFICATIONS

PART NUMBER		MAX. AXIAL DEFLECTION		MAX. AXIAL LOAD	
NATURAL RUBBER	NEOPRENE	in	mm	lb	N
2104-70	2104-80	.02	.508	55	245



TITLE: 2104

THE INFORMATION CONTAINED IN THIS DRAWING IS THE SOLE PROPERTY OF EBCU. ANY REPRODUCTION IN PART OR AS A WHOLE WITHOUT THE WRITTEN PERMISSION OF EBCU IS PROHIBITED.

TOLERANCES PER RMA STANDARD A3

REV. B

DATE: 08-09-13

UNITS: INCH [MM]

1330 HOLMES RD. ELGIN, IL 60123

SPECIFICATIONS SUBJECT TO CHANGE