

1103

DWG. NO.

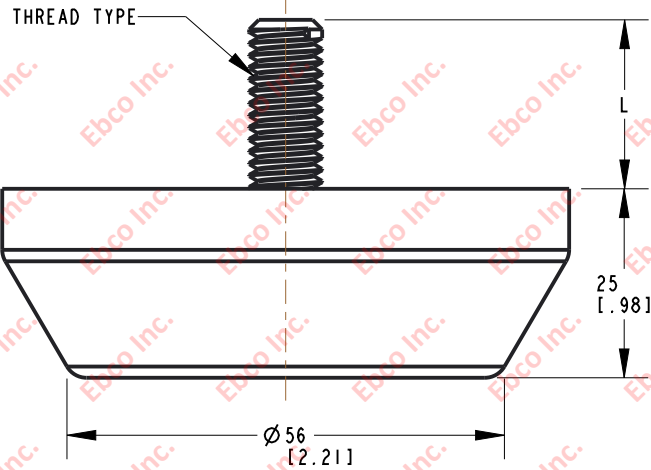
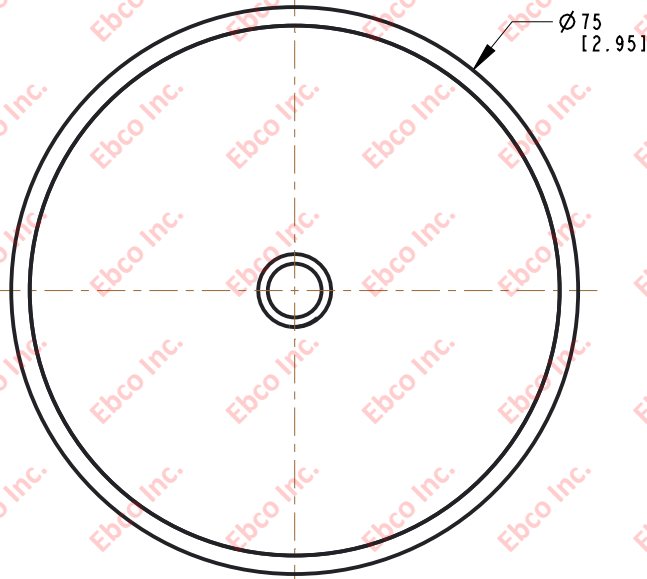

HARDWARE SPECIFICATIONS

PART NO.	THREAD TYPE	L
1103-XX-H7	3/8-16	22,4 [.881]

AXIAL COMPRESSION SPECIFICATIONS

PART NUMBER		MAX. RECOMMENDED STATIC LOAD		REFERENCE STIFFNESS	
NATURAL RUBBER	NEOPRENE	lb	N	lb/in	N/mm
1103-73-XX	1103-83-XX	325	1446	3250	569
1103-74-XX	1103-84-XX	375	1668	3750	656
1103-75-XX	1103-85-XX	425	1890	4250	744



TITLE: 1103

THE INFORMATION CONTAINED IN THIS DRAWING IS THE SOLE PROPERTY OF EBCO ANY REPRODUCTION IN PART OR AS A WHOLE WITHOUT THE WRITTEN PERMISSION OF EBCO IS PROHIBITED.

TOLERANCES PER RMA STANDARD A3	REV. B	DATE: 06-14-21
		UNITS: mm [INCH]

1330 HOLMES RD. ELGIN, IL 60123

SPECIFICATIONS SUBJECT TO CHANGE