

1102

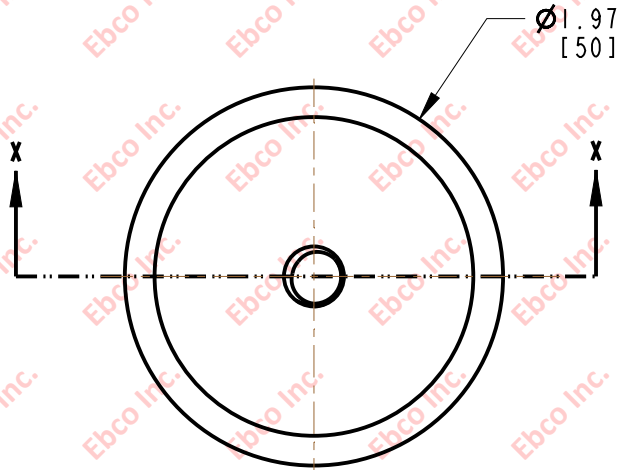

THREAD TYPE

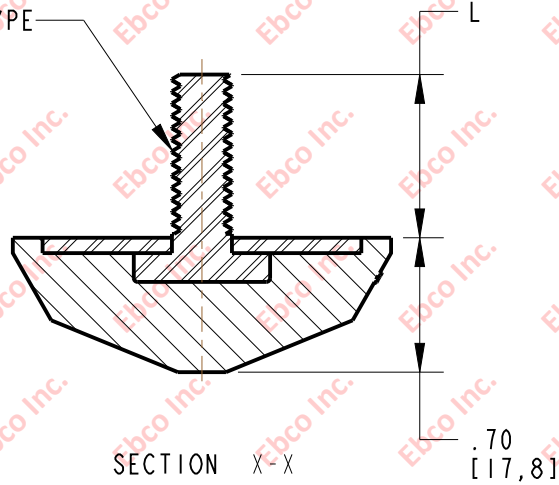

HARDWARE SPECIFICATIONS

PART NO.	THREAD TYPE	L
1102-XX-F7	5/16-18	.85 [21.6]
1102-XX-H9	3/8-16	1.10 [27.9]
1102-XX-Q9	M10X1.5	1.10 [28]

AXIAL COMPRESSION SPECIFICATIONS

PART NUMBER		REF MAX. RECOMMENDED STATIC LOAD		REFERENCE STIFFNESS	
NATURAL RUBBER	NEOPRENE	lb	N	lb/in	N/mm
1102-72-XX	1102-82-XX	19	85	271	47
1102-76-XX	1102-86-XX	45	200	643	112



TITLE: 1102		
THE INFORMATION CONTAINED IN THIS DRAWING IS THE SOLE PROPERTY OF EBCO ANY REPRODUCTION IN PART OR AS A WHOLE WITHOUT THE WRITTEN PERMISSION OF EBCO IS PROHIBITED.		
TOLERANCES PER RMA STANDARD A3	REV. D	DATE: 03-19-20
		UNITS: INCH [MM]
1330 HOLMES RD. ELGIN, IL 60123		

SPECIFICATIONS SUBJECT TO CHANGE