

1085

DRG NO.

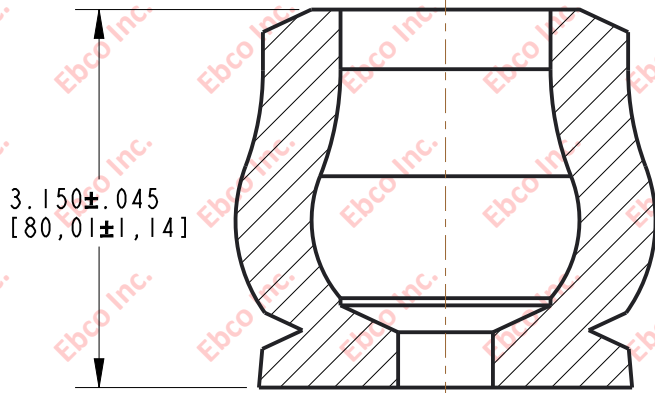
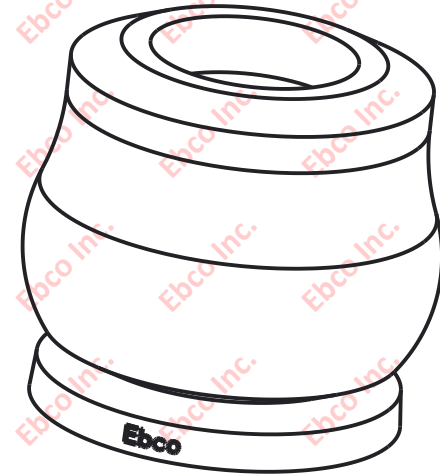
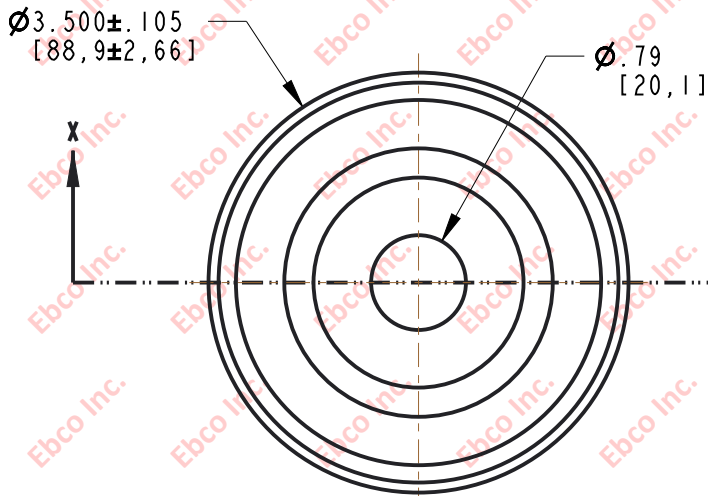

SECTION X-X

PART NUMBER	AXIAL DEFLECTION		AXIAL LOAD	
	in	mm	lb	N
HYTREL 1085-HI	1.00	25,4	8000	35586



TITLE: 1085	
THE INFORMATION CONTAINED IN THIS DRAWING IS THE SOLE PROPERTY OF EBSCO ANY REPRODUCTION IN PART OR AS A WHOLE WITHOUT THE WRITTEN PERMISSION OF EBSCO IS PROHIBITED.	
TOLERANCES PER RMA STANDARD A3	REV. B
DATE: 01-11-19	UNITS: INCH [MM]

1330 HOLMES RD. ELGIN, IL 60123

SPECIFICATIONS SUBJECT TO CHANGE