

1061

DWG. NO.

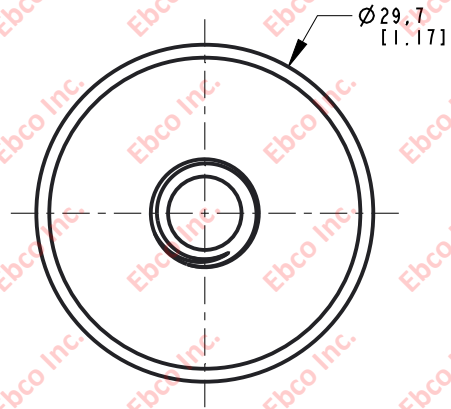

THREAD TYPE

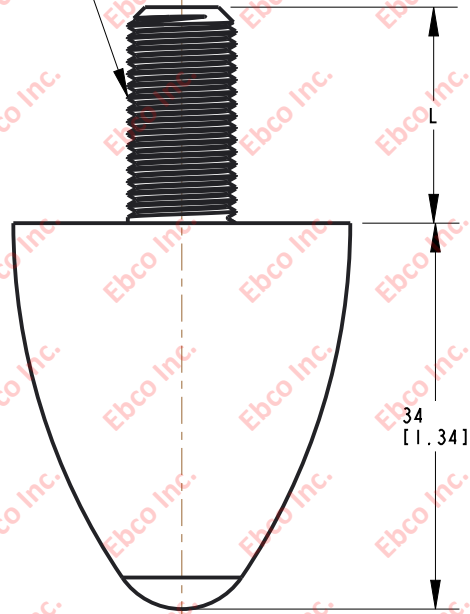

HARDWARE SPECIFICATIONS

PART NO.	THREAD TYPE	L
1061-XX-F6	5/16-18	19.1 [.75]

AXIAL COMPRESSION SPECIFICATIONS

PART NUMBER		MAX. RECOMMENDED STATIC LOAD		REFERENCE STIFFNESS	
NATURAL RUBBER	NEOPRENE	lb	N	lb/in	N/mm
1061-75-XX	1061-85-XX	20	89	135	24
1061-76-XX	1061-86-XX	35	156	235	41

TITLE: 1061

THE INFORMATION CONTAINED IN THIS DRAWING IS THE SOLE PROPERTY OF EBCO ANY REPRODUCTION IN PART OR AS A WHOLE WITHOUT THE WRITTEN PERMISSION OF EBCO IS PROHIBITED.

TOLERANCES PER RMA STANDARD A3
 REV. B
 DATE: 06-14-21
 UNITS: mm [INCH]



1330 HOLMES RD. ELGIN, IL 60123

SPECIFICATIONS SUBJECT TO CHANGE