

1031

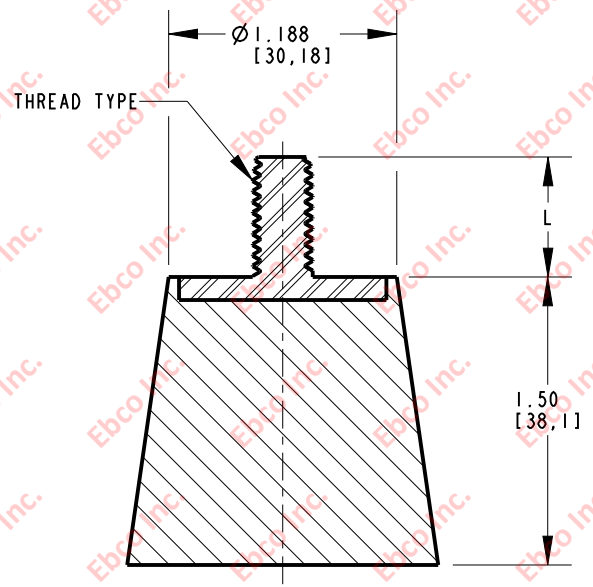
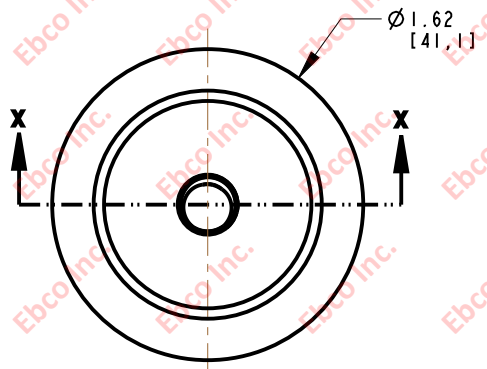

HARDWARE SPECIFICATIONS

PART NO.	THREAD TYPE	L
1031-XX-F5	5/16-18	.625 [15, 9]

AXIAL COMPRESSION SPECIFICATIONS

PART NUMBER		MAX. RECOMMENDED STATIC LOAD		REFERENCE STIFFNESS	
NATURAL RUBBER	NEOPRENE	lb	N	lb/in	N/mm
1031-73-XX	1031-83-XX	80	356	530	93



TITLE: 1031	
THE INFORMATION CONTAINED IN THIS DRAWING IS THE SOLE PROPERTY OF EBCO ANY REPRODUCTION IN PART OR AS A WHOLE WITHOUT THE WRITTEN PERMISSION OF EBCO IS PROHIBITED.	
TOLERANCES PER RMA STANDARD A3	REV. B
DATE: 04-28-14	UNITS: INCH [MM]
1330 HOLMES RD. ELGIN, IL 60123	

SPECIFICATIONS SUBJECT TO CHANGE