

1001

Ø .75  
[19]

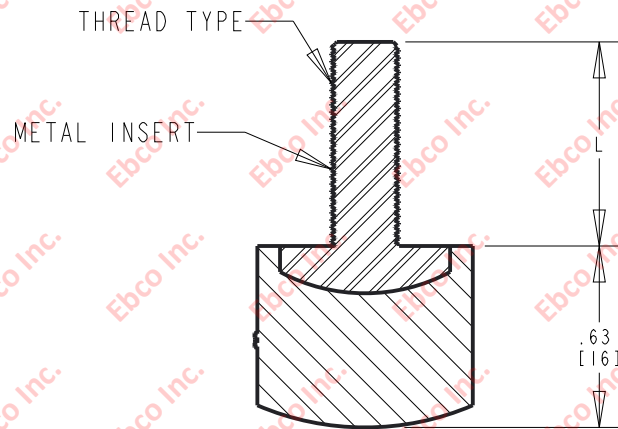
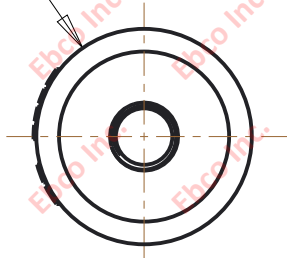

SECTION X-X

NOTE:  
1. INSERT MATERIAL: STEEL

AXIAL COMPRESSION SPECIFICATIONS

PART NUMBER		MAX. AXIAL DEFLECTION		MAX. AXIAL LOAD	
NATURAL RUBBER	NEOPRENE	in	mm	lb	N
1001-78-XX	1001-88-XX	0.06	1.524	45	200

HARDWARE SPECIFICATIONS

PART NO.	THREAD TYPE	L
1001-XX-N4	M6X1.0	0.71 [18]

	TITLE: 1001		
	<small>THE INFORMATION CONTAINED IN THIS DRAWING IS THE SOLE PROPERTY OF EBCO AND REPRODUCTION IN PART OR AS A WHOLE WITHOUT THE WRITTEN PERMISSION OF EBCO IS PROHIBITED.</small>		
	TOLERANCES PER RMA STANDARD A3	REV. <b>A</b>	DATE: 10-14-19 UNITS: INCH [MM]
	1330 HOLMES RD. ELGIN, IL 60123		
SPECIFICATIONS SUBJECT TO CHANGE			