

2310

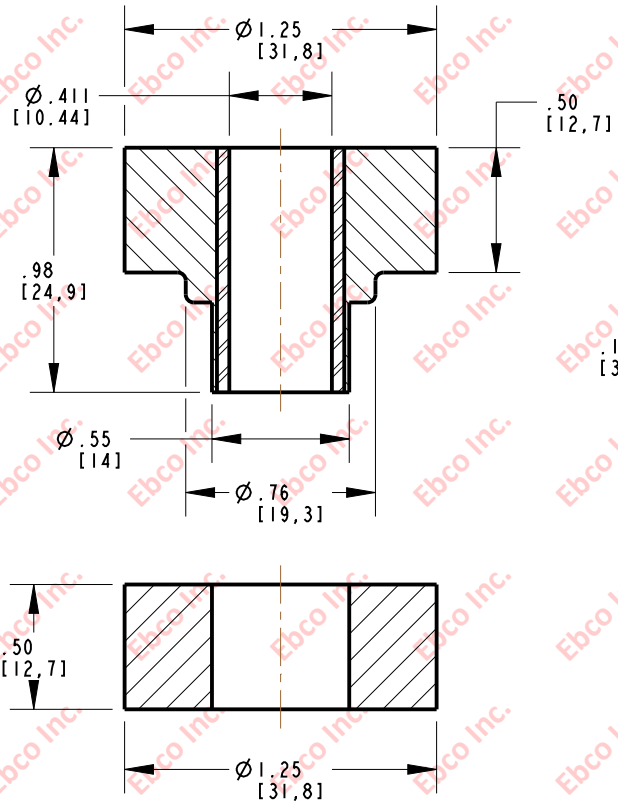

INSTALLATION VIEW (Shown under no load)

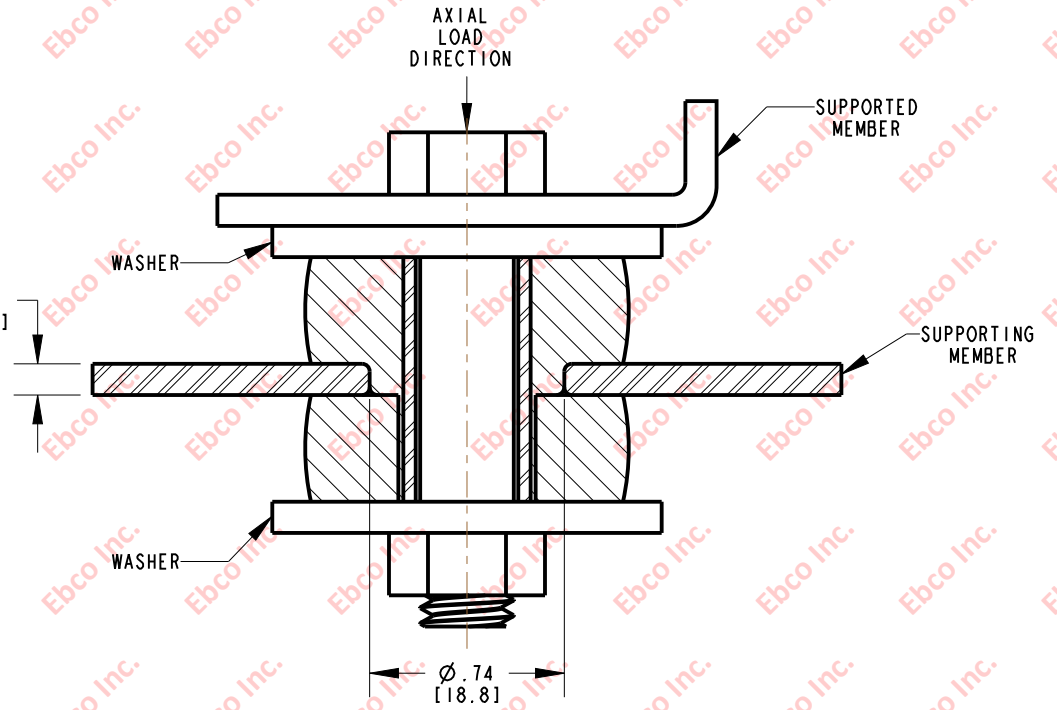

INSTALLATION DIMENSIONS

RECOMMENDED BOLT INFORMATION				TIGHTENING TORQUE			
ENGLISH		METRIC		CLAMP LOAD		TIGHTENING TORQUE	
SIZE	GRADE	SIZE	CLASS	lb	N	ft-lb	N-m
3/8	2	M10	5.8	3197	16500	20.0	33.1
WASHER SPECIFICATIONS							
O.D.		I.D.		THICKNESS			
in	mm	in	mm	in	mm		
1.56	39.62	.391	9.93	.125	3.18		

SPECIFICATIONS

PART NUMBER		MAX. AXIAL DEFLECTION		MAX. AXIAL LOAD	
NATURAL RUBBER	NEOPRENE	in	mm	lb	N
2310-70	2310-80	.05	1.27	60	267
2310-71	2310-81			70	311
2310-73	2310-83			110	489
2310-75	2310-85			175	778



TITLE: 2310
 THE INFORMATION CONTAINED IN THIS DRAWING IS THE SOLE PROPERTY OF EBCO ANY REPRODUCTION IN PART OR AS A WHOLE WITHOUT THE WRITTEN PERMISSION OF EBCO IS PROHIBITED.
 TOLERANCES PER RMA STANDARD A3
 REV. D
 DATE: 01-18-19
 UNITS: INCH [MM]
 1330 HOLMES RD. ELGIN, IL 60123

SPECIFICATIONS SUBJECT TO CHANGE